

# AIRSTAGE

AIR TO WATER

**Monobloc**

# FUJITSU

REFRIGERANT **R32**  
INVERTER

## DESIGN & TECHNICAL MANUAL

---

---

MONOBLOC UNIT



WPEG050KRF



WPEG080KRF  
WPEG100KRF

---

HYDRAULIC UNIT



WSEP100KR3

---

**FUJITSU GENERAL LIMITED**

DA\_MO004ES\_04  
2024.10.09

**Notices:**

- Product specifications and design are subject to change without notice for future improvement.
- For further details, please check with our authorized dealer.

**Trademarks**

Wi-Fi® is a trademark or registered trademark of Wi-Fi Alliance.

# CONTENTS

**1. MONOBLOC UNIT**

**2. HYDRAULIC UNIT**

**3. CONTROL SYSTEM**



## 1. MONOBLOC UNIT

# CONTENTS

## 1. MONOBLOC UNIT

<b>1. Specifications</b> .....	<b>01-1</b>
1-1. Nominal capacity and nominal input .....	01-1
1-2. Technical specifications .....	01-2
1-3. Electrical specifications .....	01-2
1-4. Product information .....	01-3
<b>2. Dimensions</b> .....	<b>01-5</b>
2-1. Model: WPEG050KRF .....	01-5
2-2. Models: WPEG080KRF and WPEG100KRF .....	01-6
<b>3. Installation space</b> .....	<b>01-7</b>
3-1. Space requirement .....	01-7
<b>4. Piping diagrams</b> .....	<b>01-9</b>
4-1. Model: WPEG050KRF .....	01-9
4-2. Models: WPEG080KRF and WPEG100KRF .....	01-10
<b>5. Wiring diagrams</b> .....	<b>01-11</b>
5-1. Model: WPEG050KRF .....	01-11
5-2. Models: WPEG080KRF and WPEG100KRF .....	01-12
<b>6. External input and output</b> .....	<b>01-13</b>
6-1. External input .....	01-13
6-2. External output .....	01-15
<b>7. Function settings (only for 080—100 models)</b> .....	<b>01-17</b>
7-1. Control PCB and switch buttons location .....	01-17
7-2. Local setting procedure .....	01-19
<b>8. Error codes</b> .....	<b>01-21</b>
<b>9. Heating capacity table</b> .....	<b>01-22</b>
9-1. Model: WPEG050KRF .....	01-22
9-2. Model: WPEG080KRF .....	01-22
9-3. Model: WPEG100KRF .....	01-23
<b>10. Cooling capacity table</b> .....	<b>01-24</b>
10-1. Model: WPEG050KRF .....	01-24
10-2. Model: WPEG080KRF .....	01-24
10-3. Model: WPEG100KRF .....	01-24
<b>11. Operation noise (sound pressure)</b> .....	<b>01-25</b>
11-1. Noise level curve .....	01-25
11-2. Sound level check point .....	01-26
<b>12. Operation range</b> .....	<b>01-27</b>
12-1. Models: WPEG050KRF, WPEG080KRF, and WPEG100KRF .....	01-27
<b>13. Hydraulic performance</b> .....	<b>01-28</b>
13-1. Models: WPEG050KRF, WPEG080KRF, and WPEG100KRF .....	01-28
<b>14. Safety devices</b> .....	<b>01-29</b>

## CONTENTS (continued)

<b>15. Accessories .....</b>	<b>01-30</b>
15-1.Models: WPEG050KRF, WPEG080KRF, and WPEG100KRF .....	01-30





# 1. Specifications

## 1-1. Nominal capacity and nominal input

Model name				WPEG050KRF	WPEG080KRF	WPEG100KRF
Power supply				1 Ø 230 V ~ 50 Hz		
Air: +7°C Water: +35°C	Heating capacity	Minimum	kW	1.92	3.35	
		Nominal		5.00	8.00	10.00
		Maximum		8.10	13.07	14.99
	Input power	Nominal	kW	1.00	1.57	2.13
Air: +7°C Water: +55°C	Heating capacity	Nominal	kW	4.99	5.08	4.70
		Nominal		5.00	8.00	10.00
		Nominal		1.72	2.62	3.40
	Input power	Nominal	kW	2.91	3.05	2.94
Air: -7°C Water: +35°C	Heating capacity	Nominal	kW	5.10	8.18	9.53
		Nominal		1.75	2.70	3.23
		Nominal		2.92	3.03	2.95
	Input power	Nominal	kW	4.80	7.50	8.50
Air: -7°C Water: +55°C	Heating capacity	Nominal	kW	2.51	3.62	4.11
		Nominal		1.91	2.07	2.07
	COP	Nominal				

**NOTE:** Test conditions are complied with EN14511:2022

## 1-2. Technical specifications

Model name				WPEG050KRF	WPEG080KRF	WPEG100KRF	
Enclosure	Material			Steel sheet			
	Color			Dark gray Approximate color of Munsell N 3.30/0.0 Stone gray Approximate color of Munsell 6.0Y 6.10/0.5			
Dimensions (H × W × D)	Net			798 × 1,080 × 480	1,008 × 1,080 × 480		
	Gross			986 × 1,174 × 600	1,196 × 1,174 × 600		
Weight	Net			85	109		
	Gross			100	123		
Main components	Pump			Wilo Para 8 m IPWM			
	Input power			W			
	Water side heat exchanger			Type × Qty			
	Water flow rate			Minimum Heating l/min			
Water circuit	Piping connection			in			
	Piping			in			
	Safety valve			bar			
	Manometer			No			
	Air purge valve			Yes			
	Heat exchanger	Dimensions (H × W × D)		mm	756 × 1,199 × 18.19	966 × 1,193 × 36.38	
Fin pitch		1.45					
Rows × Stages				1.5 × 36	2 × 46		
Pipe type			Copper				
Fin type		Type (Material)			Corrugate (Aluminum)		
		Surface treatment			Corrosion resistance (Blue fin)		
Fan	Airflow rate	Heating		m <sup>3</sup> /h	3,060	3,590	
	Type × Qty			Propeller fan × 1			
	Discharge direction			Horizontal			
	Motor quantity			1			
	Motor output			W	100	111	
Compressor	Type			DC twin rotary			
	Motor output			W	1,200	2,180	
Operation range	Ambient temperature	Heating	Minimum	°CDB	-20		
			Maximum		35		
	Water temperature	Heating	Minimum	°C	17		
			Maximum		60		
Refrigerant	Type (Global Warming Potential)			R32 (675)			
	Charge			g	880	1,470	
	Control			Expansion valve (electric type)			
	Number of circuits			1			
Refrigerant oil	Type			RmM68 Ester			
	Charged volume			l	0.55	0.80	
Defrost method				Reverse cycle			
Defrost control				Heat pump side exchanger temperature sensor			
Capacity control method				Inverter control			

## 1-3. Electrical specifications

Model name				WPEG050KRF	WPEG080KRF	WPEG100KRF
Available voltage range				220—240 V		
Power supply	Voltage		V			
	Frequency		Hz			
Maximum operating current	Heating		A	14.6	19.1	20.6
	Main fuse (circuit breaker) current			16	25	
Wiring specifications*1	Power cable		mm <sup>2</sup>	1.5 or more	4.0 or more	
	Transmission cable			1.5 or more		
Wiring connection quantity*2	For power supply		N°	3		
	For connection with indoor			4		
<b>NOTES:</b>						
<ul style="list-style-type: none"> <li>*1: Wiring specification is selected based on Japan Electrotechnical Standard and Codes Committee E0005.</li> <li>*2: Earth wiring is included.</li> </ul>						

## 1-4. Product information

Model name			WPEG050KRF		WPEG080KRF		WPEG100KRF		
Air-to-water heat pump			Yes						
Water-to-water heat pump			No						
Brine-to-water heat pump			No						
Low-temperature heat pump			No						
Equipped with a supplementary heater			Yes						
Heat pump combination heater			No*3						
Temperature application			°C		55	35	35	55	35
Rated heat output*1	P <sub>rated</sub>	kW	6	6	9	9	10	10	
Seasonal space heating energy efficiency	η <sub>s</sub>	%	133	189	139	195	141	195	
Declared capacity for heating for part load at indoor temperature 20 °C and outdoor temperature T <sub>j</sub>									
T <sub>j</sub> = -7°C	P <sub>dh</sub>	kW	4.9	5.1	7.7	8.0	8.8	9.0	
T <sub>j</sub> = +2°C	P <sub>dh</sub>	kW	3.0	3.1	4.7	4.8	5.3	5.5	
T <sub>j</sub> = +7°C	P <sub>dh</sub>	kW	1.9	2.0	3.7	3.9	3.7	4.0	
T <sub>j</sub> = +12°C	P <sub>dh</sub>	kW	2.4	2.5	4.4	4.5	4.4	4.5	
T <sub>j</sub> = Bivalent temperature	P <sub>dh</sub>	kW	4.9	5.1	7.7	8.0	8.8	9.0	
T <sub>j</sub> = Operation limit temperature	P <sub>dh</sub>	kW	4.7	5.0	7.4	7.9	8.0	9.0	
T <sub>j</sub> = -15°C (if TOL < -20°C)	P <sub>dh</sub>	kW	—	—	—	—	—	—	
Bivalent temperature	T <sub>biv</sub>	°C	-7	-7	-7	-7	-7	-7	
Cycling interval capacity for heating	P <sub>cych</sub>	kW	Not applicable						
Degradation co-efficient*2	C <sub>dh</sub>		0.94	0.92	0.97	0.96	0.96	0.96	
Declared coefficient of performance or primary energy ratio for part load at indoor temperature 20 °C and outdoor temperature T <sub>j</sub>									
T <sub>j</sub> = -7°C	COP <sub>d</sub>		2.08	3.15	2.26	3.19	2.16	3.06	
T <sub>j</sub> = +2°C	COP <sub>d</sub>		3.46	4.80	3.40	4.90	3.53	4.92	
T <sub>j</sub> = +7°C	COP <sub>d</sub>		4.26	6.33	4.83	6.54	4.87	6.61	
T <sub>j</sub> = +12°C	COP <sub>d</sub>		6.23	8.19	6.45	8.45	6.74	8.30	
T <sub>j</sub> = Bivalent temperature	COP <sub>d</sub>		2.08	3.15	2.26	3.19	2.16	3.06	
T <sub>j</sub> = Operation limit temperature	COP <sub>d</sub>		1.84	2.74	2.01	2.79	1.94	2.71	
T <sub>j</sub> = -15°C (if TOL < -20°C)	COP <sub>d</sub>		—	—	—	—	—	—	
Operation limit temperature	TOL	°C	-10	-10	-10	-10	-10	-10	
Cycling interval efficiency	COP <sub>cyc</sub>		Not applicable						
Heating water operating limit temperature	WTOL	°C	60	60	60	60	60	60	
Power consumption in modes other than active mode									
Off mode	P <sub>OFF</sub>	kW	0.013	0.013	0.013	0.013	0.013	0.013	
Thermostat-off mode	P <sub>TO</sub>	kW	0.023	0.023	0.023	0.023	0.023	0.023	
Standby mode	P <sub>SB</sub>	kW	0.013	0.013	0.013	0.013	0.013	0.013	
Crankcase heater mode	P <sub>CK</sub>	kW	0.000	0.000	0.000	0.000	0.000	0.000	
Supplementary heater									
Rated heat output*1	P <sub>SUP</sub>	kW	0.8	0.8	1.3	1.1	1.9	1.2	
Type of energy input	Electric								
Other items									
Capacity control			Variable						
Sound power level	Indoor unit	L <sub>WA</sub>	40	—	40	—	40	—	
	Outdoor unit	L <sub>WA</sub>	52	—	56	—	57	—	
Annual energy consumption	Q <sub>HE</sub>	kWh	3,355	2,503	5,078	3,764	5,685	4,269	
Emissions of nitrogen oxides	NO <sub>x</sub>	mg/kWh	Not applicable						
Rated airflow rate		m <sup>3</sup> /h	3,060		3,590		3,590		
Daily fuel consumption	Q <sub>fuel</sub>	kWh	Not applicable						
Contact details			FUJITSU GENERAL (EURO) GmbH Fritz-Vomfelde-Straße 26-32, 40547 Düsseldorf, Germany						
<b>NOTES:</b>									
<ul style="list-style-type: none"> <li>Product information according to Commission Delegated Regulation (EU) 813/2013</li> <li>Product information is based on the average climate condition.</li> <li>*1: For heat pump space heaters and heat pump combination heaters, the rated heat output P<sub>rated</sub> is equal to the design load for heating P<sub>design,h</sub>, and the rated heat output of a supplementary heater P<sub>sup</sub> is equal to the supplementary capacity for heating sup (T<sub>j</sub>).</li> <li>*2: If C<sub>dh</sub> is not determined by measurement then the default degradation coefficient is C<sub>dh</sub> = 0.9.</li> <li>*3: Possible with using an optional component.</li> </ul>									

## ■ Product fiche

Model name		WPEG050KRF			WPEG080KRF			WPEG100KRF	
Temperature application	°C	55	35	55	35	55	35	55	35
Rated heat output	kW	6	6	9	9	10	10	10	10
Seasonal space heating energy efficiency	%	133	189	139	195	141	195	141	195
Annual energy consumption	kWh	3,355	2,503	5,078	3,764	5,685	4,269	5,685	4,269
Annual electricity consumption	kWh	—	—	—	—	—	—	—	—
Specific precautions in assembled, installed, or maintained		Refer to the installation and operating manuals.							
Rated heat output	Colder climate	kW	—	—	—	—	—	—	—
	Warmer climate	kW	6	6	8	9	9	11	11
Annual energy consumption	Colder climate	kWh	—	—	—	—	—	—	—
	Warmer climate	kWh	1,889	1,316	2,462	1,984	2,783	2,317	2,317
Seasonal space heating energy efficiency	Colder climate	%	—	—	—	—	—	—	—
	Warmer climate	%	161	245	171	245	174	245	242
Sound power level	dB	52			56			57	

**NOTES:**

- Product fiche according to Commission Delegated Regulation (EU) 811/2013
- Acoustic noise information:
  - The maximum sound power level is less than 70 dB (A) for outdoor unit.
  - According to IEC 704-1 and ISO 3744.
- If the air to water heat pump is operated under higher temperature conditions than those listed, the built-in protection circuit may operate to prevent internal circuit damage. Also, during cooling modes, if the unit is used under conditions of lower temperatures than those listed above, the heat exchanger may freeze, leading to water leakage and other damage.
- Do not use this unit for any purposes other than the Heating and Cooling.

## ■ Energy efficiency value

Application: 35°C										
Model name		WPEG050KRF			WPEG080KRF			WPEG100KRF		
Seasonal energy efficiency of heat pump for space heating	%	189			195			195		
Type of temperature control										
Outdoor sensor		II	—	—	II	—	—	II	—	—
Room thermostat		—	V	—	—	V	—	—	V	—
Outdoor sensor + Room thermostat		—	—	VI	—	—	VI	—	—	VI
Bonus	%	2	3	4	2	3	4	2	3	4
Seasonal space heating energy efficiency of package in average climate conditions	%	191	192	193	197	198	199	197	198	199
Seasonal space heating energy efficiency of package in warmer climate conditions	%	247	248	249	247	248	249	244	245	246
Seasonal space heating energy efficiency of package in colder climate conditions	%	—	—	—	—	—	—	—	—	—

Application: 55°C										
Model name		WPEG050KRF			WPEG080KRF			WPEG100KRF		
Seasonal energy efficiency of heat pump for space heating	%	133			139			141		
Type of temperature control										
Outdoor sensor		II	—	—	II	—	—	II	—	—
Room thermostat		—	V	—	—	V	—	—	V	—
Outdoor sensor + Room thermostat		—	—	VI	—	—	VI	—	—	VI
Bonus	%	2	3	4	2	3	4	2	3	4
Seasonal space heating energy efficiency of package in average climate conditions	%	135	136	137	141	142	143	143	144	145
Seasonal space heating energy efficiency of package in warmer climate conditions	%	163	164	165	173	174	175	176	177	178
Seasonal space heating energy efficiency of package in colder climate conditions	%	—	—	—	—	—	—	—	—	—

## ■ Class of temperature controller

Controller class		II	V	VI
Contribution to energy efficiency	%	2	3	4

## 2. Dimensions

### 2-1. Model: WPEG050KRF

Unit: mm

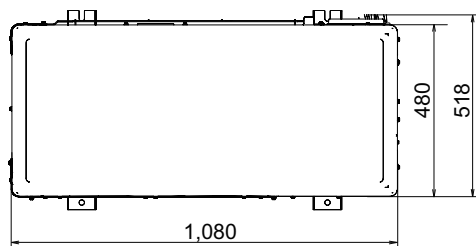

Top view

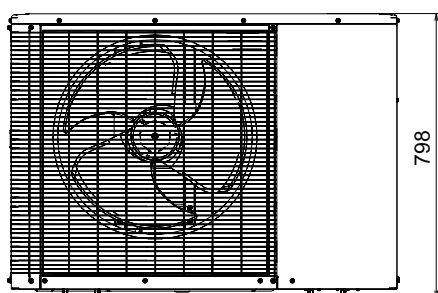

Front view

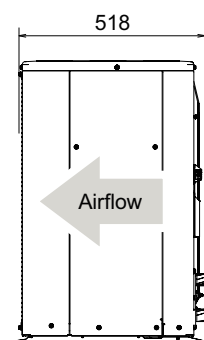

Side view (R)

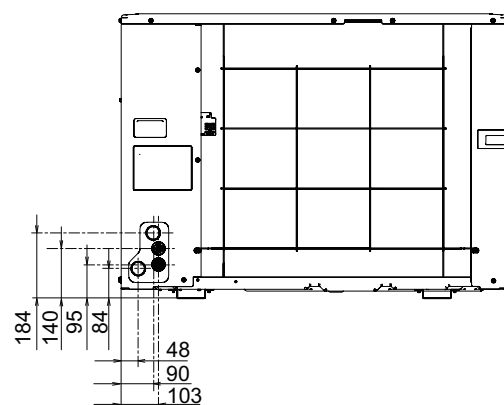

Rear view

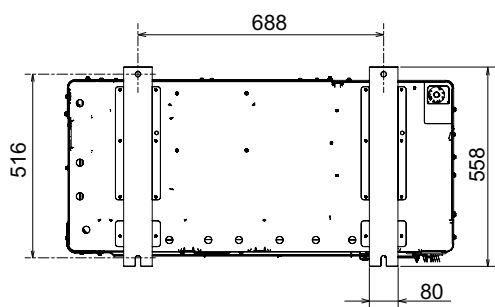

Bottom view

## 2-2. Models: WPEG080KRF and WPEG100KRF

Unit: mm

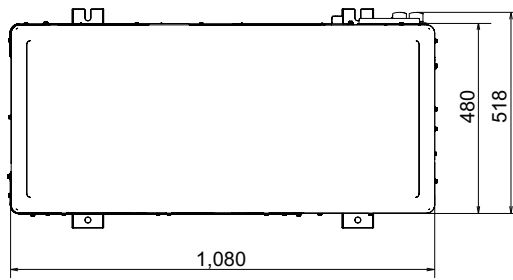

Top view

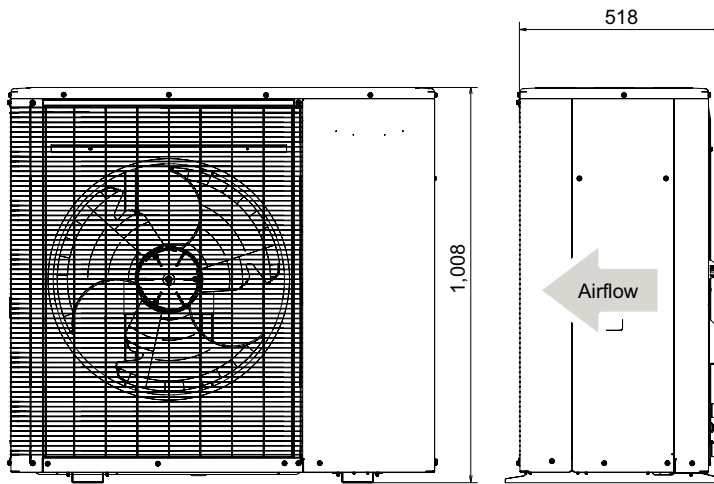

Front view

Side view (R)

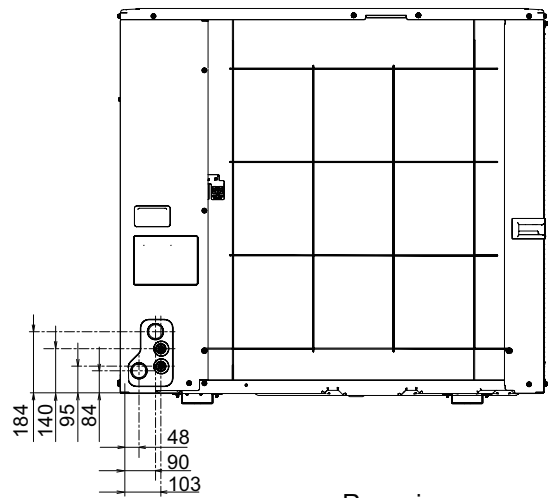

Rear view

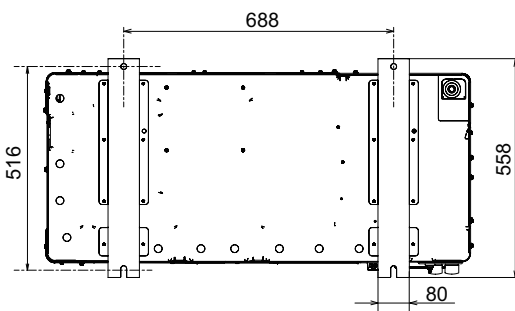

Bottom view

## 3. Installation space

### 3-1. Space requirement

Provide sufficient installation space for product safety.

#### ⚠ CAUTION

Keep the space shown in the installation examples.

If the installation is not performed accordingly, it could cause a short circuit and result in a lack of operating performance.

#### ● Single outdoor unit installation

- When the upper space is open:

Unit: mm

When there are obstacles at the rear only.

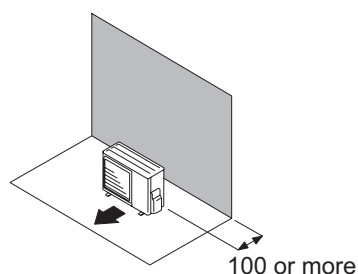

When there are obstacles at the rear and sides.

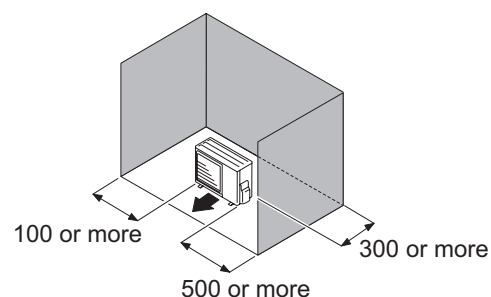

When there are obstacles at the front only.

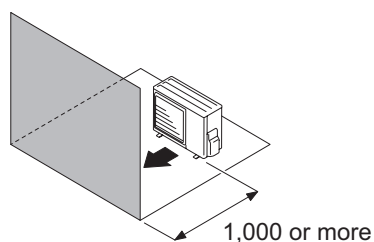

When there are obstacles at the front and rear.

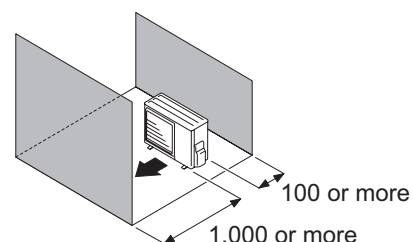

- When an obstruction in the upper space:

Unit: mm

When there are obstacles at the rear and above.

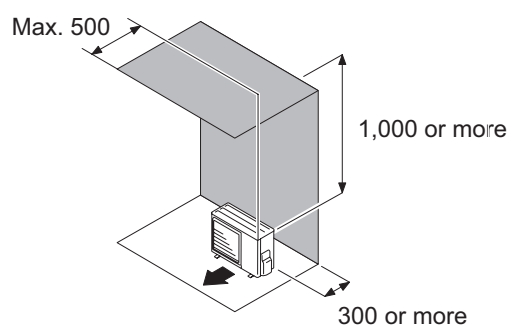

When there are obstacles at the rear, sides, and above.

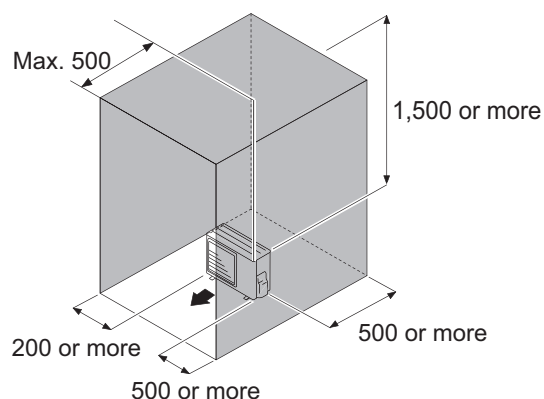

## ● Multiple outdoor unit installation

- Provide at least 250 mm of space between the outdoor units if multiple units are installed.
- When routing the piping from the side of an outdoor unit, provide space for piping.
- No more than 3 units must be installed side by side.  
When 4 units or more are arranged in a line, provide the space as shown in the following example **“When an obstruction in the upper space:”**.

- **When the upper space is open:**

Unit: mm

When there are obstacles at the rear only.

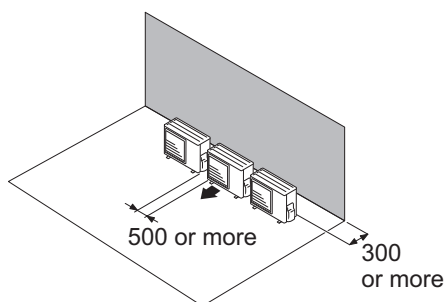

When there are obstacles at the front only.

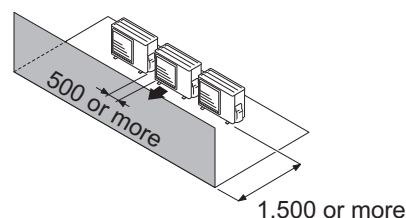

When there are obstacles at the front and rear.

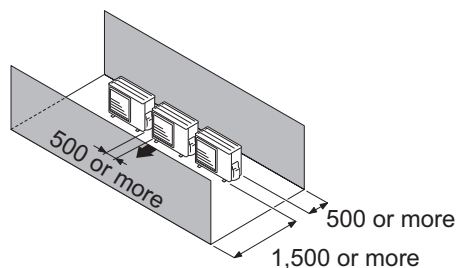

## ● Outdoor unit position

- The outdoor unit must be raised by at least 50 mm from the ground.  
In snowy regions, the height must be increased but must not exceed 1.5 m.
- Fasten the outdoor unit using screws and elastic tightening or toothed lock washers to prevent them from coming loose.

### ⚠ CAUTION

In regions with heavy snowfall, if the outdoor unit's entrance and exit are blocked by snow it may be difficult to heat up and may cause breakdown.

- Build a canopy or position the unit on a high stand (locally purchased).
  - Put the appliance on a solid support to minimize impact and vibration.
  - Do not set the unit directly on the ground as this may generate disruptions.

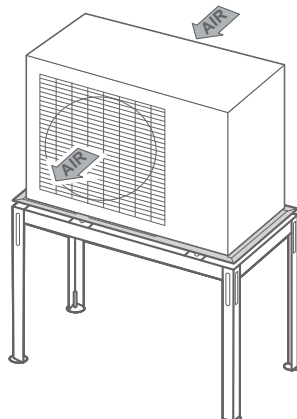



## 4. Piping diagrams

### 4-1. Model: WPEG050KRF

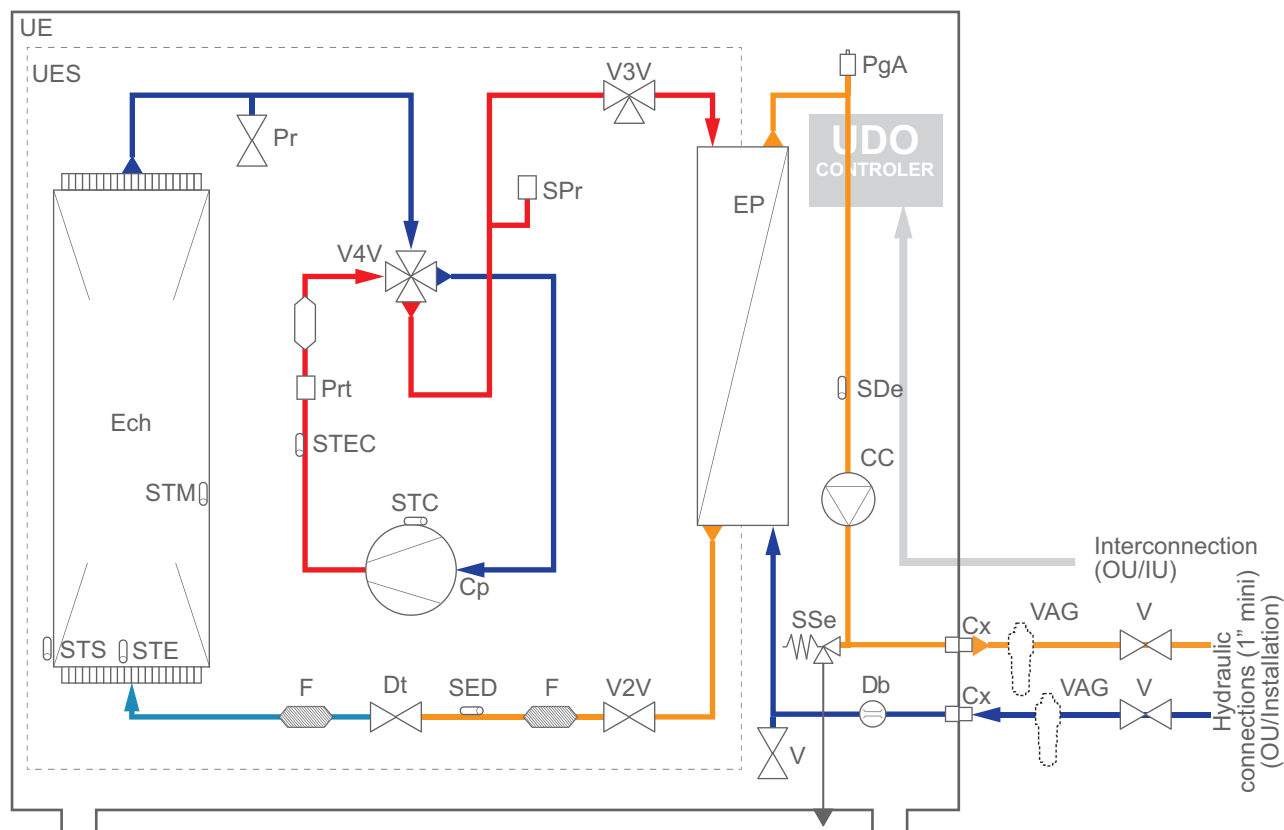

Abbreviation	Part name	Abbreviation	Part name
CC	HP circulation pump IPWM	SSe	Pressure relief valve
Cp	Compressor	STC	Compressor temp. sensor
Cx	Hydraulic connection 1"	STE	Outdoor temp. sensor
Db	Flow meter	STEC	Discharge temp. sensor
Dt	Expansion valve	STM	Heat exchanger middle temp. sensor
Ech	Air to refrigerant heat exchanger	STS	Heat exchanger liquid temp. sensor
EP	Refrigerant to water heat exchanger	UE	Outdoor unit
F	Filter	UES	Refrigerant unit
PgA	Automatic bleeder valve (Air purge valve)	V	Valve
Pr	Schrader valve	V2V	2-way valve
Prt	High pressure switch	V3V	3-way valve
SDe	Water outlet temp. sensor	V4V	4-way valve
SED	Electric expansion valve sensor	VAG	Antifreeze valve
SPr	Pressure sensor		

## 4-2. Models: WPEG080KRF and WPEG100KRF

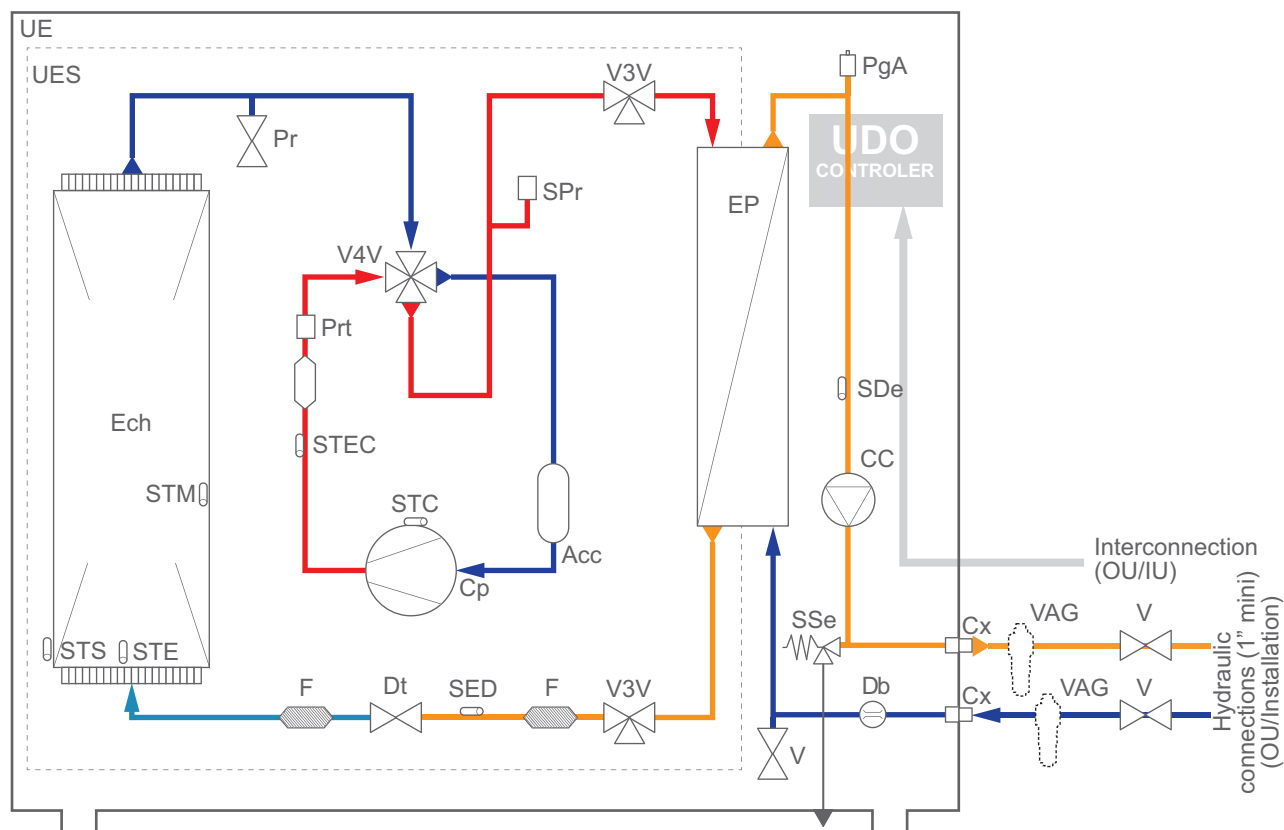

Abbreviation	Part name	Abbreviation	Part name
Acc	Accumulator	SPr	Pressure sensor
CC	HP circulation pump IPWM	SSe	Pressure relief valve
Cp	Compressor	STC	Compressor temp. sensor
Cx	Hydraulic connection 1"	STE	Outdoor temp. sensor
Db	Flow-meter	STEC	Discharge temp. sensor
Dt	Expansion valve	STM	Heat exchanger middle temp. sensor
Ech	Air to refrigerant heat exchanger	STS	Heat exchanger liquid temp. sensor
EP	Refrigerant to water heat exchanger	UE	Outdoor unit
F	Filter	UES	Refrigerant unit
PgA	Automatic bleeder valve (Air purge valve)	V	Valve
Pr	Schrader valve	V3V	3-way valve
Prt	High pressure switch	V4V	4-way valve
SDe	Water outlet temp. sensor	VAG	Antifreeze valve
SED	Electric expansion valve sensor		

# 5. Wiring diagrams

## 5-1. Model: WPEG050KRF

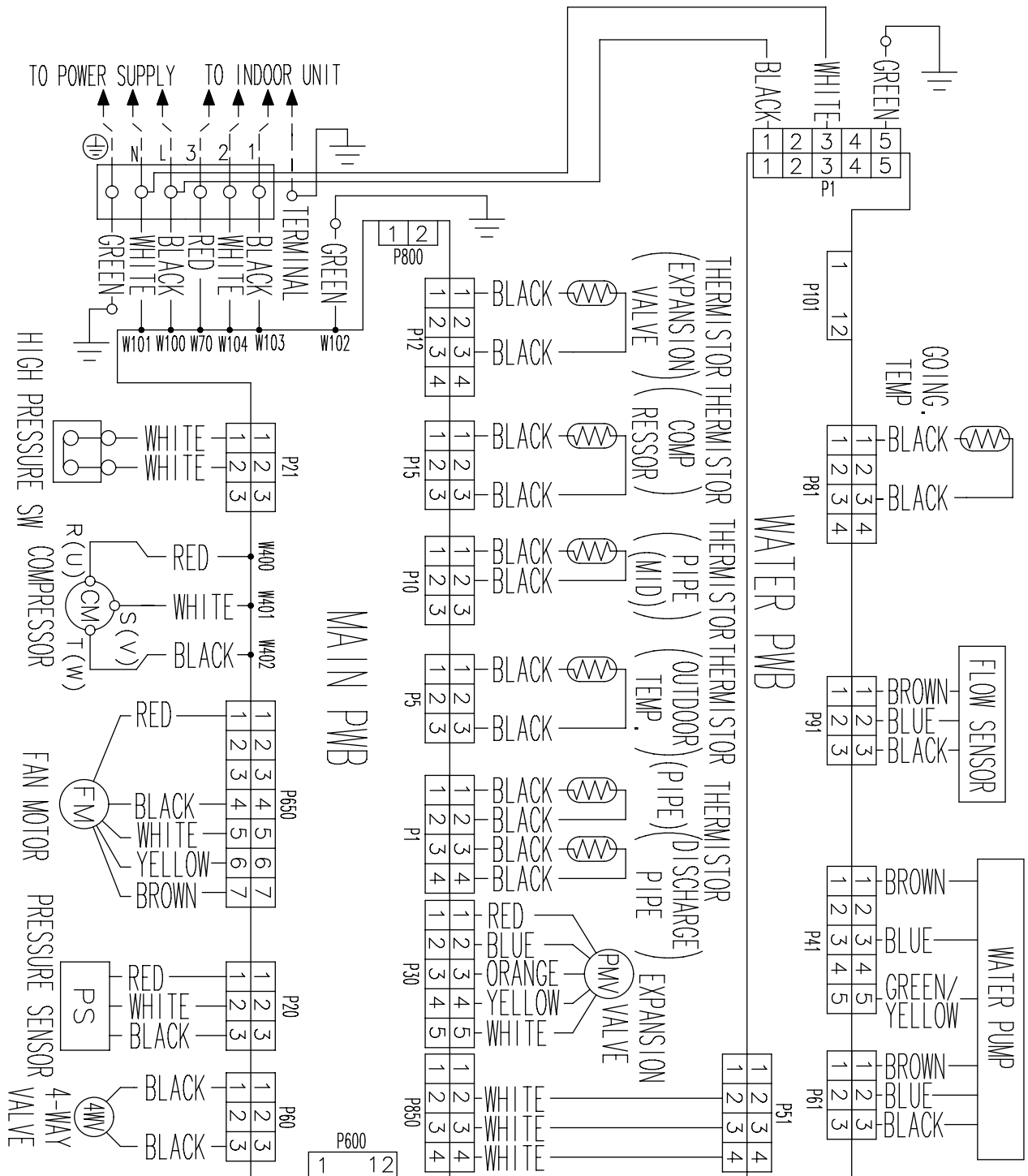

# 5-2. Models: WPEG080KRF and WPEG100KRF

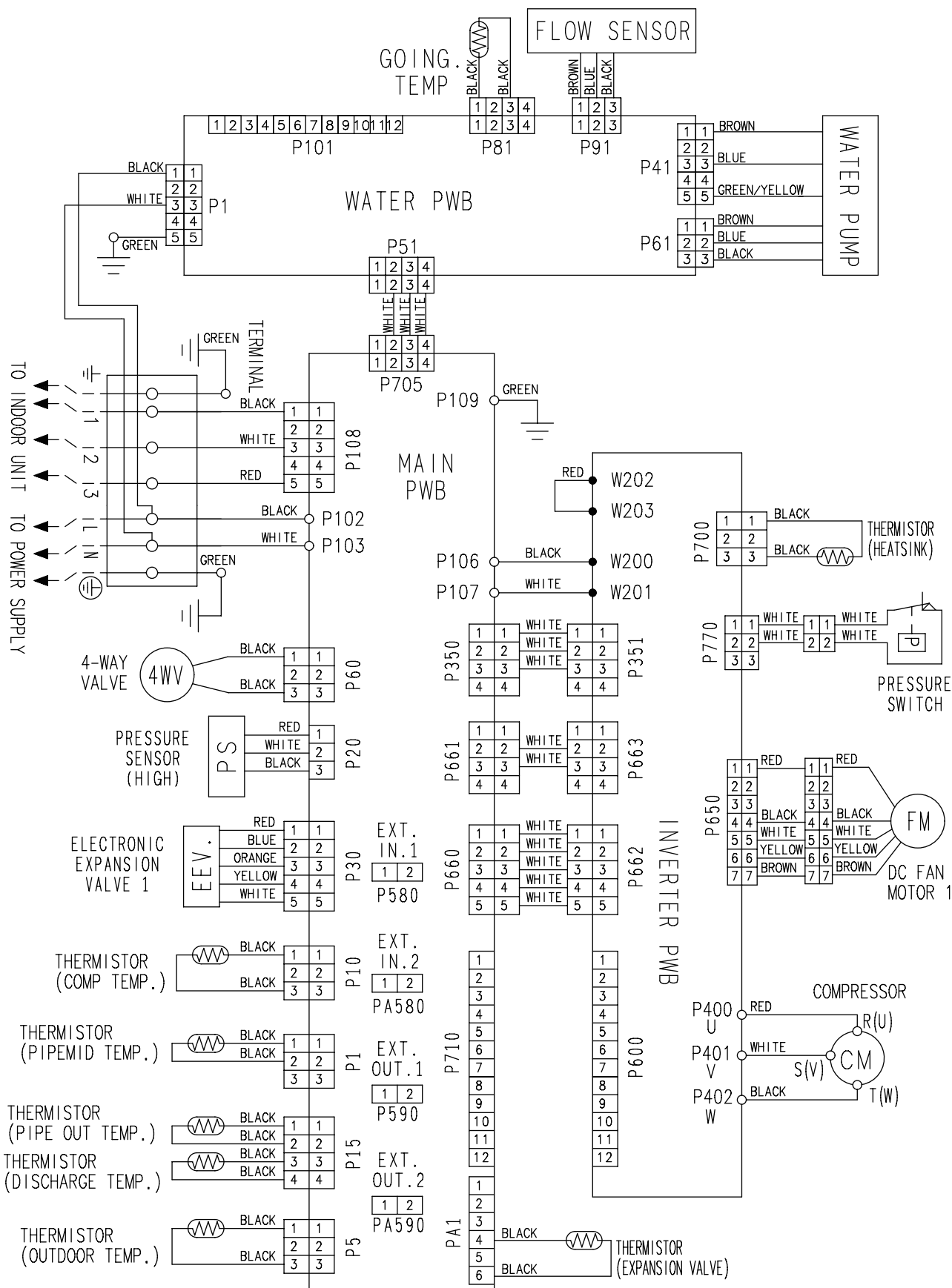

## 6. External input and output

With using external input and output functions, this product can be operated inter-connectedly with an external device.

Function		Connector		Remarks
		WPEG050KRF	WPEG080KRF WPEG100KRF	
Input	Low noise mode	—	P580	See external input/output settings for details.
	Peak cut mode	—	PA580	
Output	Base heater control	P800	P590	
	Compressor status	—	PA590	

### 6-1. External input

With using external input function, on/off status of “Low noise mode” and “Peak cut mode” can be specified by the external signal.

#### ■ Low noise mode

In following condition, the operating noise of the outdoor unit reduces comparing from the one in normal operating condition:

The outdoor unit is set to the “Low noise mode” when closing the contact input of a commercial timer or on/off switch to a connector on the control PCB of the outdoor unit.

**NOTE:** Product performance may drop depending on some conditions such as the outdoor temperature.

#### • Circuit diagram example

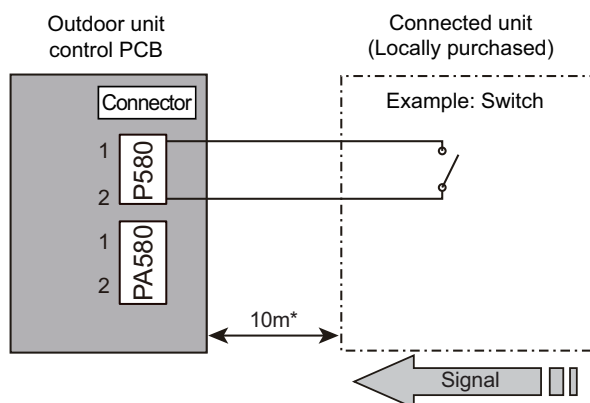

- Contact capacity: DC 24 V or more, 10 mA or more.
- \*: Make the distance from the PCB to the connected unit within 10 m.
- Construct a circuit as shown in this figure with using optional parts mentioned below.
- Input signal: On in “Low noise mode”
- Input signal: Off in normal operation
- To set the level of “Low noise mode,” refer to ["Low noise mode"](#) on page 01-19 (under “Local setting procedure”).

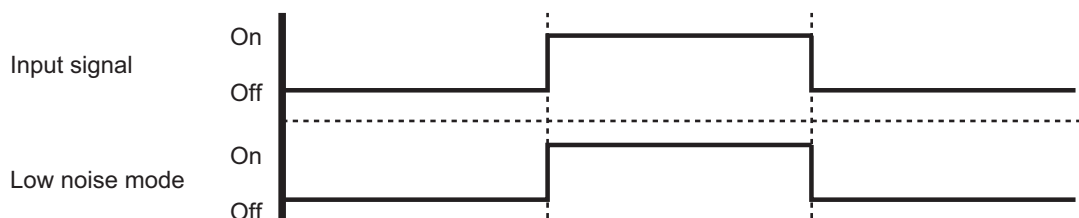

#### • Optional part

Part name	Model name	Exterior
External Connect Kit	UTY-XWZXZ3	External input wire 

## ■ Peak cut mode

By performing following on-site work, operation that suppresses the current value can be enabled: The outdoor unit is set to the “Peak cut mode” when closing the contact input of a commercial timer or on/off switch to a connector on the control PCB of the outdoor unit.

### • Circuit diagram example

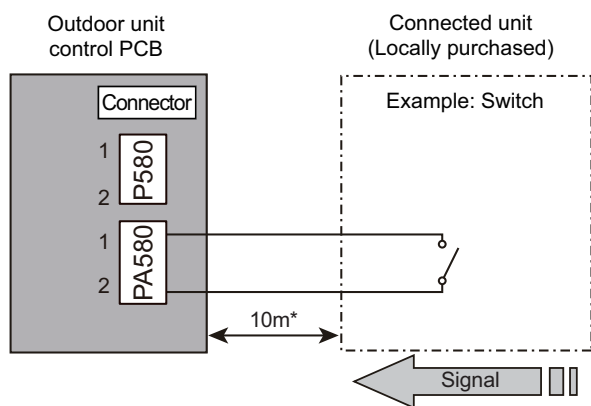

- Contact capacity: DC 24 V or more, 10 mA or more.
- \*: Make the distance from the PCB to the connected unit within 10 m.
- Construct a circuit as shown in this figure with using optional parts mentioned below.
- Input signal: On in “Peak cut mode”
- Input signal: Off in normal operation
- To set the level of “Peak cut mode,” refer to "Peak cut mode" on page 01-20 (under “Local setting procedure”).

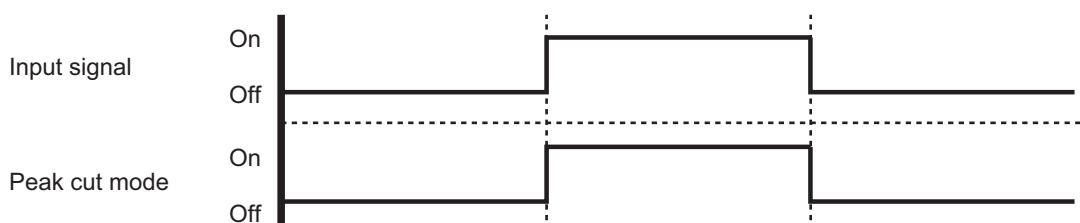

### • Optional part

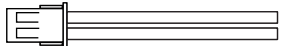
Part name	Model name	Exterior
External Connect Kit	UTY-XWZXZ3	External input wire 

## 6-2. External output

With using external output function, some status signals are transmitted to the control PCB, and the related LED lamp indicates the status of this product.

### ■ Base pan heater control output

Signal on base pan heater operation is generated to run it.

#### • Circuit diagram example

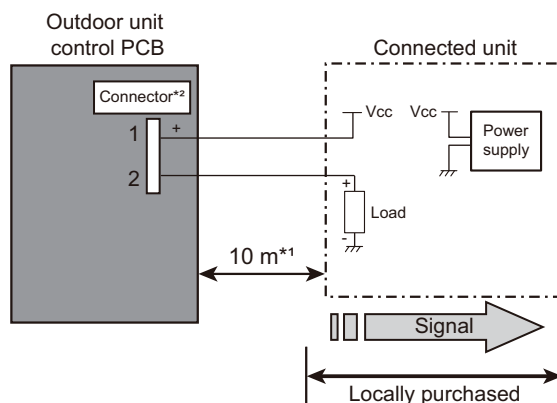

- Input voltage from external power supply: DC 24 V or less and 500 mA or less
- \*1: Make the distance from the PCB to the connected unit within 10 m.
- \*2: The connector depends on the model as follows.
  - 050 model: P800
  - 080-100 model: P590

This is the output signal for the base pan heater. The output signal is on, when the outdoor temperature drops below 2°C, and signal is off when it rises to 5°C.

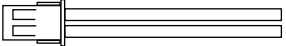

#### • Optional part

Part name	Model name	Exterior
External Connect Kit	UTY-XWZXZ3	External output wire 

## ■ Compressor status output

Signal on compressor operation status is generated when the compressor is running.

### • Circuit diagram example

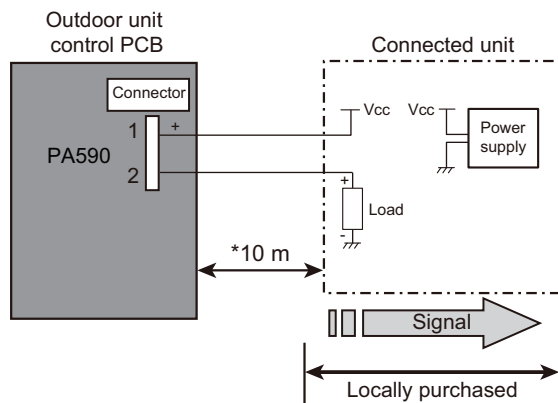

- Input voltage from external power supply: DC 24 V or less and 500 mA or less
- \*: Make the distance from the PCB to the connected unit within 10 m.

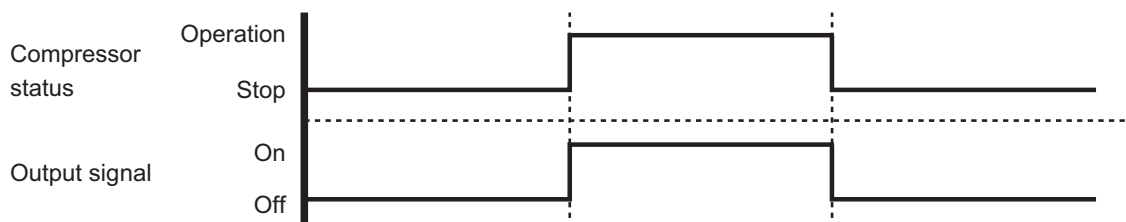

### • Optional part

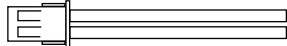
Part name	Model name	Exterior
External Connect Kit	UTY-XWZXZ3	External output wire 



## 7. Function settings (only for 080—100 models)

Perform appropriate function setting locally according to the installation environment.

**NOTE:** Incorrect settings can cause a product malfunction.

### ⚠ CAUTION

- Before setting up the switch buttons, discharge the static electricity from your body.
- Never touch the terminals or the patterns on the parts that are mounted on the PCB.

### 7-1. Control PCB and switch buttons location

Control PCB of the outdoor unit is located as shown in the following figure.

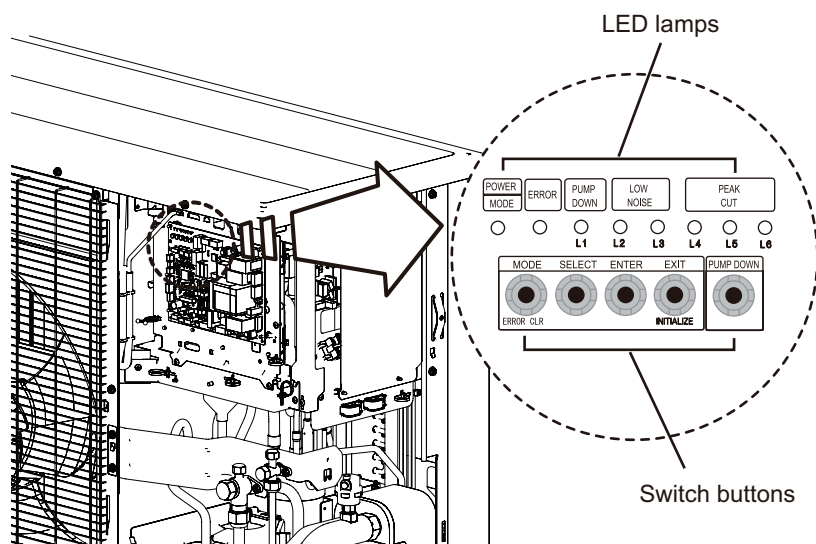

## ■ Switch buttons and the functions

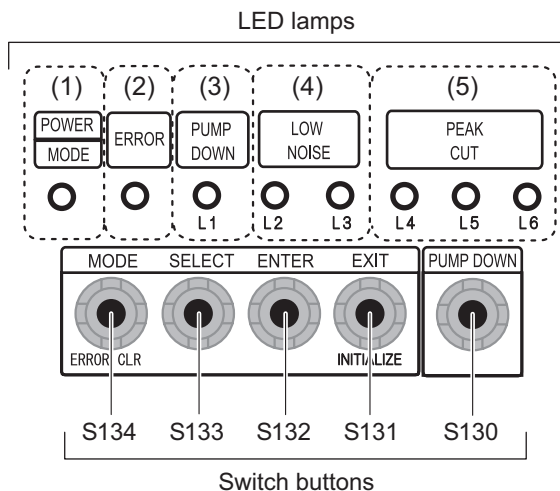

LED lamp			Function or operation method
(1)	POWER/MODE	Green	Lights on while power on. Blinks to show the local setting on the outdoor unit or the error code.
(2)	ERROR	Red	Blinks during error operation.
(3)	PUMP DOWN (L1)	Orange	Lights on during pump down operation.
(4)	LOW NOISE MODE (L2 and L3)	Orange	Lights on during "Low noise mode" when local setting is activated. (Light pattern of L2 and L3 indicates the low noise level.)
(5)	PEAK CUT MODE (L4, L5, and L6)	Orange	Lights on during "Peak cut mode" when local setting is activated. (Light pattern of L4, L5, and L6 indicates the peak cut level.)

Switch button		Function or operation method
S134	MODE	Switches between "Local setting" and "Error code display".
S133	SELECT	Switches between the individual "Local settings" and the "Error code displays".
S132	ENTER	Switches between the individual "Local settings" and the "Error code displays".
S131	EXIT	Returns to "Operation status display".
S130	PUMP DOWN	Starts the pump down operation.

## 7-2. Local setting procedure

**NOTE:** Before performing the function setting, be sure to stop the operation of the heat pump.

### ■ Low noise mode

1. Press the MODE switch button (S134) for 3 seconds or more to switch to “Local setting mode”.
2. After confirming the LED lamp of POWER/MODE blinks 9 times, press the ENTER switch button (S132).

POWER MODE	ERROR	PUMP DOWN (L1)	LOW NOISE		PEAK CUT		
			(L2)	(L3)	(L4)	(L5)	(L6)
Blinks (9 times)	○	○	○	○	○	○	○

Sign “○”: Lights off

3. Press the SELECT switch button (S133), and adjust the LED lamp as shown below. Then the LED lamp indicates the current setting.

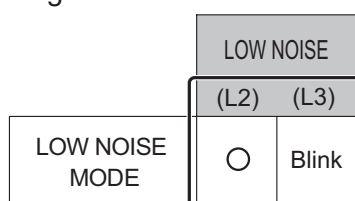

4. Press the ENTER switch button (S132).

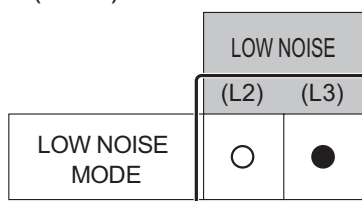

Sign “●”: Lights on

5. Press the SELECT switch button (S133), and adjust the LED lamps as shown below.

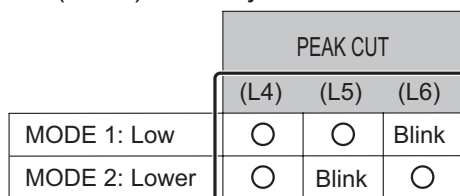

6. Press the ENTER switch button (S132) and fix it.

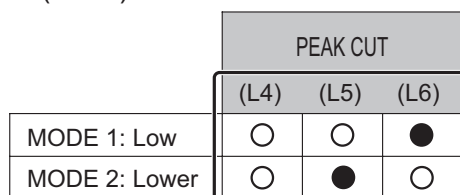

7. To return to “Operating status display (Normal operation)”, press the EXIT switch button (S131).

#### In case of missing how many times you pressed the SELECT and ENTER switch buttons:

1. To return to “Operation status display (Normal operation)”, press the EXIT switch button once.
2. Restart from the beginning of setting procedure.

## ■ Peak cut mode

1. Press the MODE switch button (S134) for 3 seconds or more to switch to “Local setting mode”.
2. After confirming the LED lamp of POWER/MODE blinks 9 times, press the ENTER switch button (S132).

POWER MODE	ERROR	PUMP DOWN (L1)	LOW NOISE		PEAK CUT		
			(L2)	(L3)	(L4)	(L5)	(L6)
Blinks (9 times)	○	○	○	○	○	○	○

Sign “○”: Lights off

3. Press the SELECT switch button (S133), and adjust the LED lamp as shown below. Then the LED lamp indicates the current setting.

		LOW NOISE	
		(L2)	(L3)
PEAK CUT MODE	Blink	○	

4. Press the ENTER switch button (S132).

		LOW NOISE	
		(L2)	(L3)
PEAK CUT MODE	●	○	

Sign “●”: Lights on

5. Press the SELECT switch button (S133), and adjust the LED lamps as shown below.

	PEAK CUT		
	(L4)	(L5)	(L6)
0 % of rated input ratio	○	○	Blink
50 % of rated input ratio	○	Blink	○
75 % of rated input ratio	○	Blink	Blink
100 % of rated input ratio	Blink	○	○

6. Press the ENTER switch button (S132) and fix it.

	PEAK CUT		
	(L4)	(L5)	(L6)
0 % of rated input ratio	○	○	●
50 % of rated input ratio	○	●	○
75 % of rated input ratio	○	●	●
100 % of rated input ratio	●	○	○

7. To return to “Operating status display (Normal operation)”, press the EXIT switch button (S131).

**NOTE:** When pressed number is lost during setting, you must redo the setting procedure. Return to “Operation status display (Normal operation)” by pressing the EXIT switch button once, and restart from the beginning of the setting procedure.

## 8. Error codes

- Outdoor unit (only for 080-100 models)

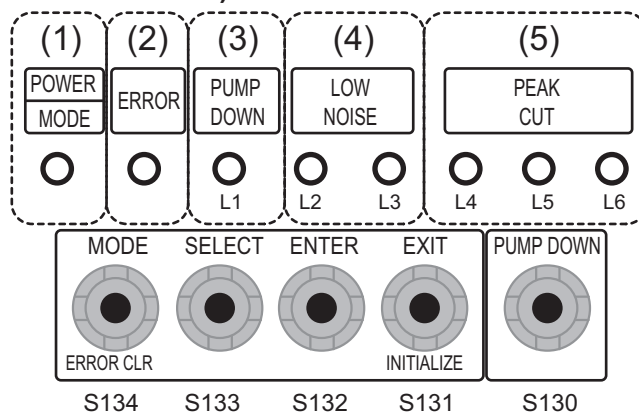

- Check that the LED of ERROR blinks, and then press shortly the switch of ENTER.
- The LED of ERROR will blink several time. For details, refer to the table below. ○: LED off, ●: LED on

Error number	Outdoor unit board						Error contents
	L1	L2	L3	L4	L5	L6	
11	1	1	○	○	●	●	Serial communication error after operation
	1	1	○	●	○	○	Serial communication error during operation
23	2	3	○	○	○	●	Different combinations used by indoor and outdoor units
	2	3	○	○	●	○	Outdoor unit PCB model information error
32	5	15	○	○	○	●	Indoor unit Main PCB error (model information error)
	5	15	○	○	●	○	Indoor unit Main PCB error (communication error)
42	5	15	○	○	○	●	Indoor unit heat exchanger sensor error
5U	5	15	○	○	○	●	Indoor unit error
62	6	2	○	○	○	●	Outdoor unit Main PCB error (model information error)
	6	2	○	○	●	○	Outdoor unit Main PCB error (communication error)
63	6	3	○	○	○	●	Inverter error
65	6	5	○	○	●	●	Outdoor unit IPM error
	6	5	○	○	○	●	IPM board temperature error
71	7	1	○	○	○	●	Discharge thermistor error
72	7	2	○	○	○	●	Compressor thermistor error
73	7	3	○	○	●	○	Heat exchanger thermistor (intermediate) error
	7	3	○	○	●	●	Heat exchanger thermistor (outlet) error
74	7	4	○	○	○	●	Outdoor thermistor error
77	7	7	○	○	○	●	Outdoor unit heat sink temperature thermistor error
78	7	8	○	○	○	●	Expansion valve thermistor error
79	7	9	○	○	●	●	Water outlet temperature thermistor error
84	8	4	○	○	○	●	Current sensor error
86	8	6	○	●	○	○	Pressure sensor error
	8	6	○	●	●	○	Pressure switch error
94	9	4	○	○	○	●	Trigger detection
95	9	5	○	○	○	●	Detection of compressor position error
	9	5	○	○	○	●	Compressor start up error
97	9	7	○	○	●	●	Outdoor unit fan1 motor error
9C	9	11	○	○	○	●	Circulation pump error
A1	10	1	○	○	○	●	Discharge temperature protection
A3	10	3	○	○	○	●	Compressor temperature protection
A5	10	5	○	○	○	●	Low pressure abnormal
AC	10	11	○	○	●	●	Outdoor unit heat sink temperature error
AP	10	14	○	○	○	●	Low water flow error



## 9-3. Model: WPEG100KRF

Outdoor temperature		Water temperature																					
		30			35			40			45			50			55			60			
		HC	IP	COP	HC	IP	COP	HC	IP	COP	HC	IP	COP	HC	IP	COP	HC	IP	COP	HC	IP	COP	
-20	5.19	2.25	2.31	5.95	2.80	2.12	5.75	3.00	1.92	5.55	3.27	1.70	—	—	—	—	—	—	—	—	—	—	—
-15	7.19	2.76	2.60	7.63	3.20	2.39	7.42	3.44	2.16	7.22	3.76	1.92	7.01	4.01	1.75	—	—	—	—	—	—	—	—
-10	8.60	2.90	2.97	9.12	3.37	2.71	8.89	3.63	2.45	8.67	3.99	2.17	8.41	4.27	1.97	7.60	4.20	1.81	—	—	—	—	—
-7	9.62	2.99	3.21	10.20	3.49	2.92	9.96	3.77	2.64	9.72	4.14	2.35	9.42	4.44	2.12	8.54	4.35	1.96	—	—	—	—	—
-5	9.84	2.98	3.30	10.43	3.50	2.98	10.19	3.77	2.70	10.00	4.16	2.40	9.75	4.47	2.18	8.91	4.38	2.03	8.19	4.45	1.84	—	—
0	11.41	3.07	3.71	12.10	3.59	3.37	11.80	3.89	3.03	11.57	4.31	2.69	11.06	4.52	2.45	10.07	4.41	2.28	9.07	4.41	2.06	—	—
5	13.82	3.30	4.19	13.86	3.62	3.83	13.57	3.95	3.44	12.57	4.10	3.06	11.56	4.10	2.82	10.41	3.99	2.61	9.33	3.99	2.34	—	—
7	15.05	3.31	4.55	14.99	3.65	4.11	14.78	4.00	3.69	13.55	4.10	3.30	12.43	4.10	3.03	11.20	3.99	2.81	10.05	3.99	2.52	—	—
10	15.93	3.27	4.88	15.98	3.63	4.41	15.66	3.98	3.93	14.28	4.06	3.52	13.06	4.06	3.22	11.76	3.95	2.98	10.54	3.95	2.67	—	—
15	14.86	2.75	5.41	13.71	2.75	4.99	12.23	2.75	4.45	10.96	2.79	3.93	10.02	2.77	3.62	8.98	2.69	3.34	7.98	2.69	2.97	—	—
20	15.03	2.37	6.35	13.22	2.37	5.58	11.86	2.37	5.00	10.60	2.40	4.42	9.57	2.37	4.03	8.45	2.30	3.67	7.25	2.30	3.15	—	—
25	15.94	2.37	6.73	14.44	2.37	6.10	13.01	2.37	5.49	11.65	2.41	4.83	10.50	2.39	4.39	9.32	2.30	4.05	8.10	2.30	3.52	—	—
30	17.78	2.37	7.51	16.41	2.37	6.93	14.44	2.37	6.10	12.93	2.41	5.36	11.64	2.41	4.82	10.33	2.30	4.48	—	—	—	—	—
35	19.14	2.37	8.09	17.62	2.37	7.44	15.53	2.37	6.56	13.88	2.41	5.75	12.48	2.41	5.17	11.02	2.31	4.78	—	—	—	—	—

## 10. Cooling capacity table

- CC: Cooling capacity (kW)
- IP: Input power (kW)
- EER: Energy Efficiency Ratio
- Usage environment, such as operation of the heating equipment, room temperature, and control adjustments may cause disparities between practically determined and measured values.
- The values mentioned in the table are calculated based on the maximum capacity:
  - The flow rate obtained with fixed delta T of 5°C with for units with a variable flow rate.

### 10-1. Model: WPEG050KRF

Outdoor temperature		Water temperature																	
		7°C			10°C			13°C			15°C			18°C			22°C		
		CC	IP	EER	CC	IP	EER	CC	IP	EER	CC	IP	EER	CC	IP	EER	CC	IP	EER
20	7.39	1.78	4.14	7.90	1.81	4.37	8.41	1.83	4.60	8.77	1.84	4.76	9.02	1.84	4.90	9.22	1.84	5.00	
25	6.93	1.85	3.75	7.36	1.85	3.99	6.94	1.84	3.76	8.11	1.84	4.40	8.29	1.84	4.49	8.47	1.84	4.60	
30	6.13	1.84	3.33	6.52	1.85	3.53	6.06	1.84	3.29	7.17	1.85	3.88	7.35	1.84	3.98	7.53	1.84	4.08	
35	5.33	1.84	2.89	5.69	1.84	3.09	6.02	1.84	3.27	6.24	1.84	3.38	6.42	1.85	3.48	6.59	1.84	3.57	
40	3.32	1.26	2.63	3.59	1.26	2.85	3.87	1.26	3.08	4.05	1.26	3.23	4.31	1.26	3.44	4.41	1.25	3.52	
46	2.61	1.27	2.06	2.83	1.27	2.23	2.97	1.26	2.35	3.12	1.26	2.47	3.33	1.26	2.64	3.59	1.26	2.85	

### 10-2. Model: WPEG080KRF

Outdoor temperature		Water temperature																	
		7°C			10°C			13°C			15°C			18°C			22°C		
		CC	IP	EER	CC	IP	EER	CC	IP	EER	CC	IP	EER	CC	IP	EER	CC	IP	EER
20	9.85	2.11	4.67	12.15	2.69	4.51	12.97	2.72	4.77	13.49	2.72	4.96	14.27	2.72	5.25	14.03	2.71	5.18	
25	9.27	2.28	4.07	11.39	2.99	3.81	12.08	3.02	4.01	12.55	3.03	4.15	13.26	3.04	4.37	13.38	2.71	4.94	
30	8.73	2.55	3.42	10.60	3.26	3.25	11.28	3.33	3.39	11.68	3.34	3.50	12.29	3.34	3.68	12.44	3.34	3.73	
35	8.31	2.91	2.86	9.42	3.29	2.86	9.90	3.30	3.00	10.23	3.31	3.09	10.75	3.32	3.24	11.47	3.34	3.44	
40	5.86	2.21	2.65	6.21	2.22	2.80	6.61	2.22	2.98	6.86	2.22	3.09	7.24	2.22	3.26	7.77	2.23	3.49	
46	4.63	2.21	2.09	4.97	2.21	2.25	5.25	2.21	2.37	5.44	2.21	2.46	5.74	2.21	2.59	6.19	2.21	2.80	

### 10-3. Model: WPEG100KRF

Outdoor temperature		Water temperature																	
		7°C			10°C			13°C			15°C			18°C			22°C		
		CC	IP	EER	CC	IP	EER	CC	IP	EER	CC	IP	EER	CC	IP	EER	CC	IP	EER
20	9.85	2.11	4.67	13.43	3.28	4.10	14.24	3.31	4.30	14.79	3.33	4.44	15.59	3.34	4.68	15.60	3.33	4.68	
25	9.27	2.28	4.07	12.08	3.34	3.62	12.73	3.34	3.82	13.18	3.34	3.95	13.88	3.34	4.16	14.01	3.34	4.20	
30	8.73	2.55	3.42	10.72	3.32	3.23	11.29	3.34	3.39	11.68	3.34	3.50	12.29	3.34	3.68	12.44	3.34	3.73	
35	8.31	2.91	2.86	9.42	3.29	2.86	9.90	3.30	3.00	10.23	3.31	3.09	10.75	3.32	3.24	11.47	3.34	3.44	
40	5.86	2.21	2.65	6.21	2.22	2.80	6.61	2.22	2.98	6.86	2.22	3.09	7.24	2.22	3.26	7.77	2.23	3.49	
46	4.63	2.21	2.09	4.97	2.21	2.25	5.25	2.21	2.37	5.44	2.21	2.46	5.74	2.21	2.59	6.19	2.21	2.80	



# 11. Operation noise (sound pressure)

## 11-1. Noise level curve

■ Model: WPEG050KRF

● Heating

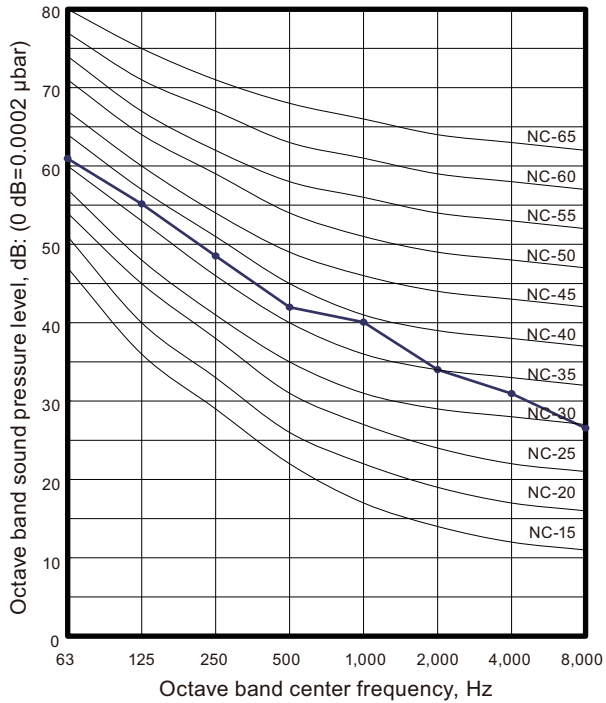

■ Model: WPEG080KRF

● Heating

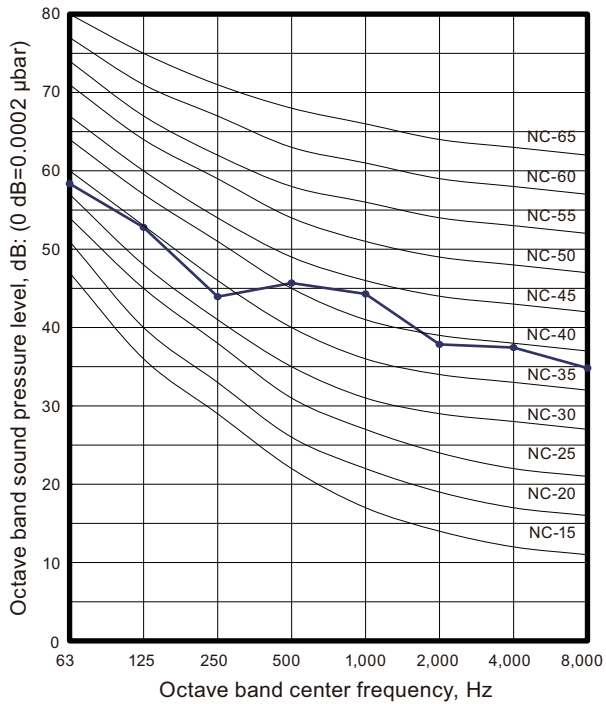

# Model: WPEG100KRF

## ● Heating

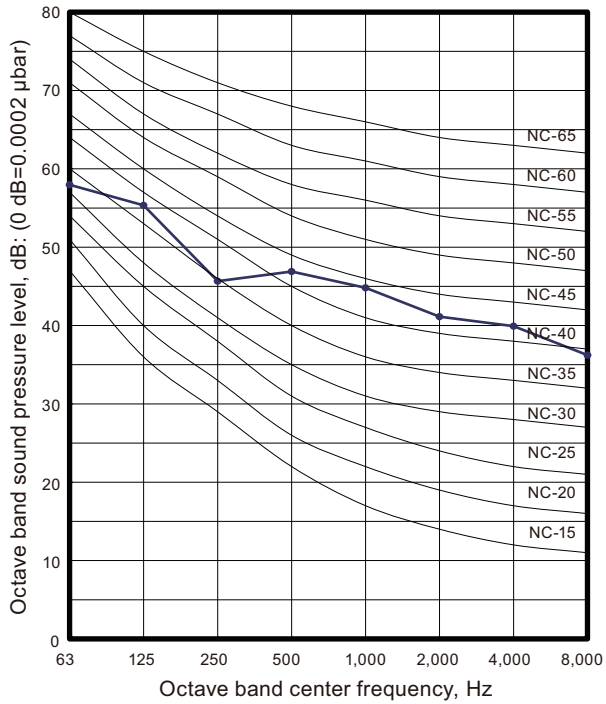

## 11-2. Sound level check point

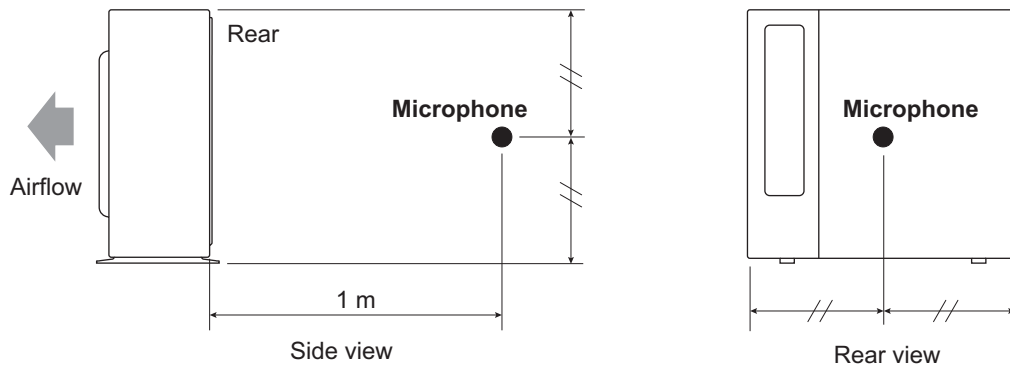

**NOTE:** Detailed shape of the actual outdoor unit might be slightly different from the one illustrated above.

## 12. Operation range

### 12-1. Models: WPEG050KRF, WPEG080KRF, and WPEG100KRF

- Operating mode: Cooling

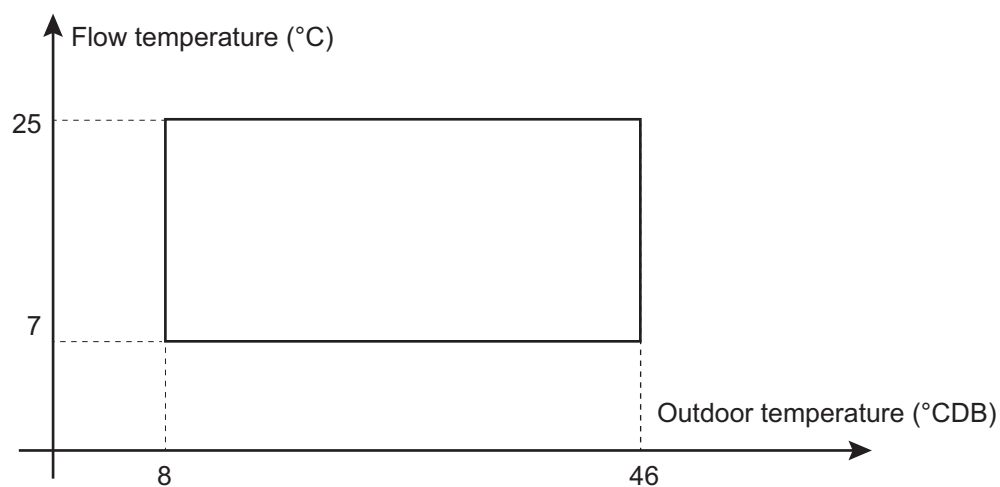

- Operating mode: Heating, Domestic hot water

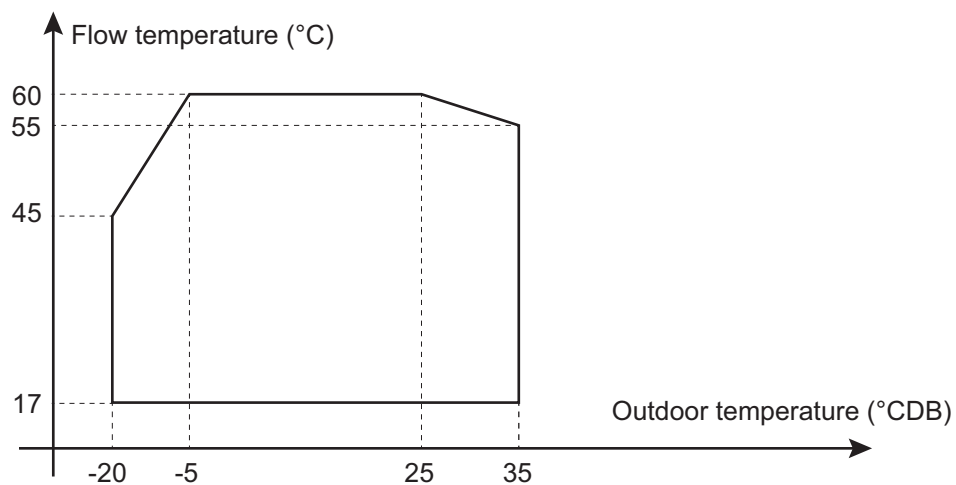

# 13. Hydraulic performance

## 13-1. Models: WPEG050KRF, WPEG080KRF, and WPEG100KRF

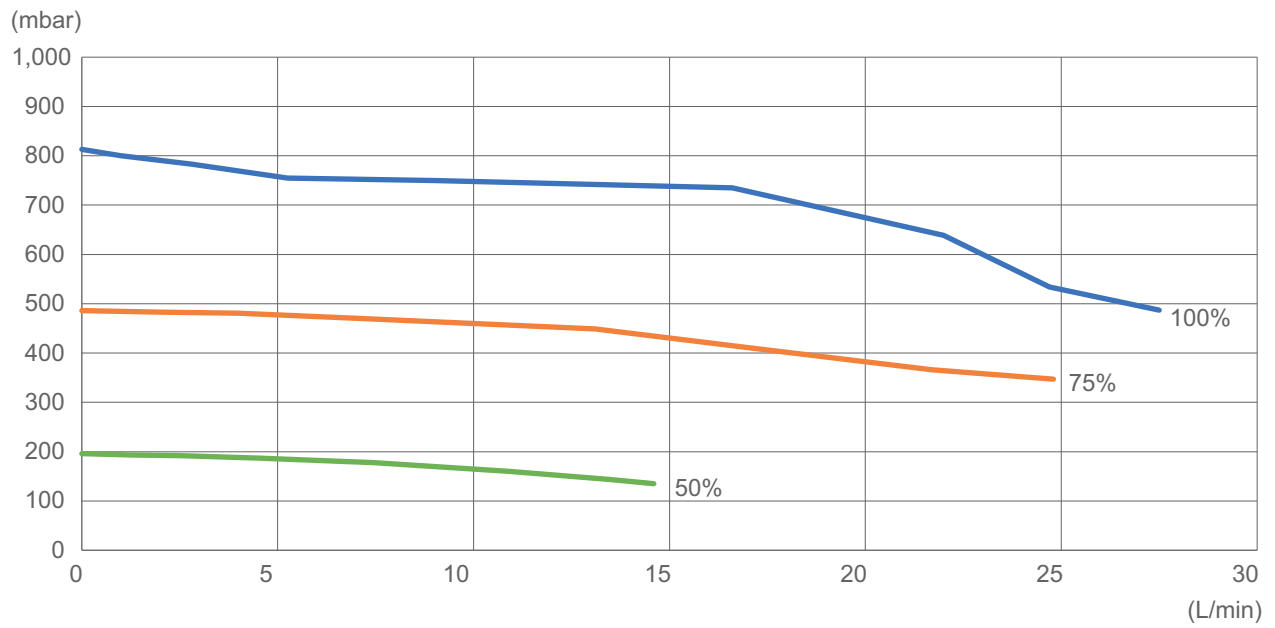







# 14. Safety devices

Type of protection	Protection form		Model	
			WPEG050KRF	WPEG080KRF WPEG100KRF
Circuit protection	Current fuse (PCB)		AC 250 V, 25 A AC 250 V, 5 A	AC 250 V, 30 A or 35.5 A AC 250 V, 10 A AC 250 V, 5 A AC 250 V, 3.15 A
Fan motor protection	Thermal protection	Activate	113—131°C Fan motor stop	115±15°C Fan motor stop
		Reset	107—126°C Fan motor restart	70°C Fan motor restart
Compressor protector	Thermal protection program (Compressor temp.)	Activate	108°C Compressor stop	
		Reset	After 3 minutes and 80°C or less Compressor restart	
	Thermal protection program (Discharge temp.)	Activate	110°C Compressor stop	
		Reset	After 7 minutes Compressor restart	
High pressure protection	Pressure switch	Activate	4.2 <sup>+0</sup> <sub>-0.15</sub> MPa Compressor stop	
		Reset	After 3 minutes and 3.2±0.15 MPa Compressor restart	
	Pressure sensor	Activate	4.1 MPa Compressor stop	
		Reset	After 3 minutes and 3.0 MPa Compressor restart	

## 15. Accessories

### 15-1. Models: WPEG050KRF, WPEG080KRF, and WPEG100KRF

Name and shape	Qty
 Installation manual	1
 Quick installation manual	1
 Product fiche	3
 Energy label	3
 Regulatory requirements of installation and maintenance	1
 Drain pipe	1
 Drain cap	9

## 2. HYDRAULIC UNIT

# CONTENTS

## 2. HYDRAULIC UNIT

<b>1. Specifications</b> .....	<b>02-1</b>
1-1. Technical specifications.....	02-1
1-2. Electrical specifications.....	02-1
<b>2. Dimensions</b> .....	<b>02-2</b>
2-1. Model: WSEP100KR3 .....	02-2
<b>3. Installation space</b> .....	<b>02-3</b>
3-1. Model: WSEP100KR3 .....	02-3
<b>4. Piping diagrams</b> .....	<b>02-4</b>
4-1. Model: WSEP100KR3 .....	02-4
<b>5. Wiring diagrams</b> .....	<b>02-7</b>
5-1. Model: WSEP100KR3 .....	02-7
<b>6. Hydraulic connections</b> .....	<b>02-8</b>
6-1. Outdoor unit.....	02-8
<b>7. Electrical connections</b> .....	<b>02-9</b>
7-1. Overview .....	02-9
7-2. Cable dimensions and protection rating.....	02-9
<b>8. Hydraulic performance</b> .....	<b>02-11</b>
8-1. Model: WSEP100KR3 .....	02-11
<b>9. Safety devices</b> .....	<b>02-12</b>
<b>10. Accessories</b> .....	<b>02-13</b>



# 1. Specifications

## 1-1. Technical specifications

Model name		Hydraulic unit		WSEP100KR3			
		Outdoor unit		WPEG050KRF	WPEG080KRF	WPEG100KRF	
Input power	Heating	Maximum*1		3 (Optional: 6)			
Enclosure		Material		Front Panel 8/10 mm DC01 + EZ (5μ)			
		Color		White			
Dimensions (H × W × D)	Net	mm		737 × 448 × 469			
	Gross			875 × 545 × 550			
Weight	Net (Empty/Full of water)		34/50				
	Gross		39				
Water capacity				16			
Main components	Pump	Type		Water cooled			
		Speed setting		Variable speed			
		Input power*3		75			
	Buffer tank	Qty		1			
		Volume		16			
	Expansion vessel	Volume		12			
		Max. water pressure		3.0			
		Pre-pressure		1 (±0.3)			
	Safety valve		bar		3		
	Manometer				Yes		
Drain valve/Fill valve				Yes			
Air purge valve				Yes			
Water circuit	Connection pipe diameter	Heating 1	mm (in)	Ø19.05 (3/4)			
		Heating 2		Ø19.05 (3/4)			
Operation range	Water side	Heating	°C	17 to 60			
<b>NOTES:</b>							
<ul style="list-style-type: none"> <li>*1: With electric backup heater</li> <li>*2: The value is at full speed and full flow.</li> </ul>							

## 1-2. Electrical specifications

Model name		Hydraulic unit		WSEP100KR3		
		Outdoor unit		WPEG050KRF	WPEG080KRF	WPEG100KRF
Electrical heater	Type			Copper 11.4 W/cm <sup>2</sup>		
	Input power	Maximum kW		3 (Optional: 6)		
	Power supply	Phase		1		
		Frequency		50		
		Voltage		230		
	Current	Running current		13.0		
Current with 6 kW backup relay kit	Running current		26.1			
Wiring spec.	Backup heater power supply	Main fuse (circuit breaker) current		16		
		Connection cable		1.5 × 3		
	Backup heater power supply with 6 kW backup relay kit	Main fuse (circuit breaker) current		32		
		Connection cable		6.0 × 3		
	Hydraulic unit to outdoor unit	Connection cable		1.5 × 4		
	Limited wiring length		m			
				Not available		

## 2. Dimensions

### 2-1. Model: WSEP100KR3

Unit: mm

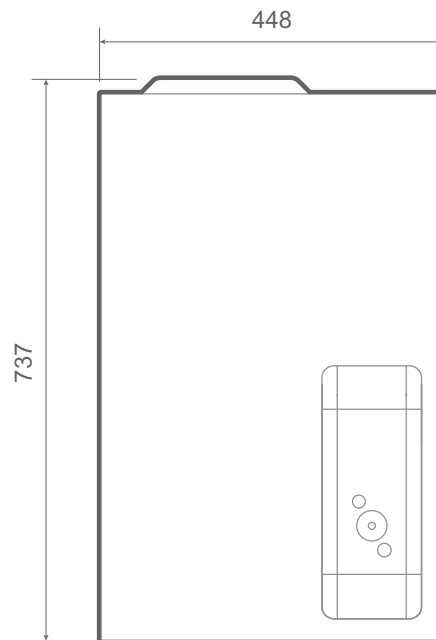
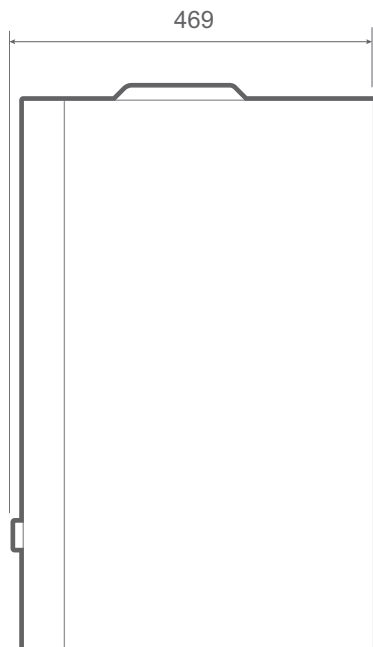
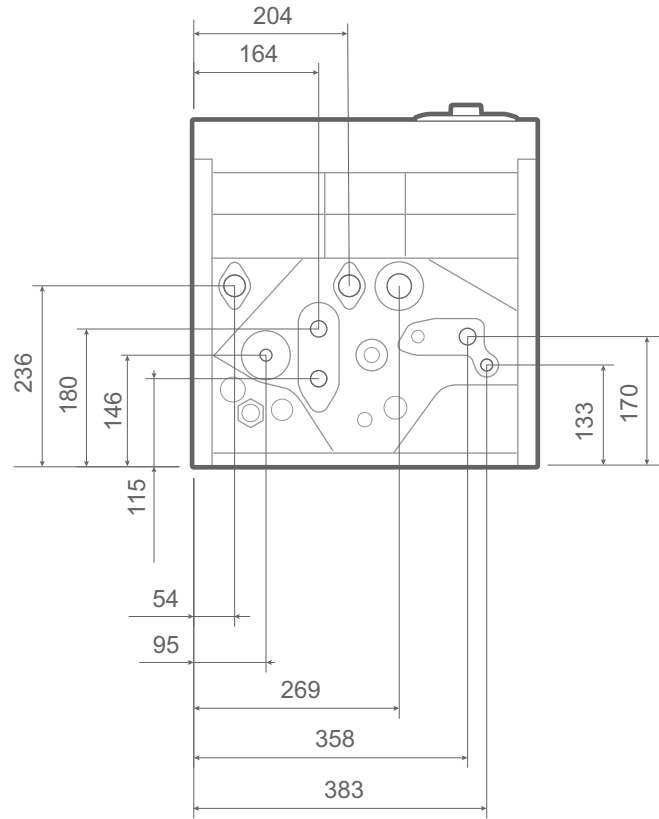

### 3. Installation space

#### 3-1. Model: WSEP100KR3

Unit: mm

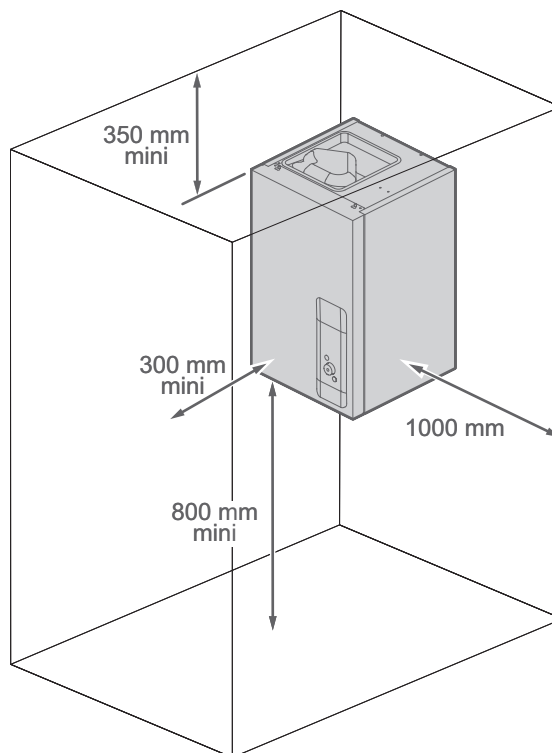

- Choose the location of the appliance after discussion with the client.
- The installation space should comply with the current regulations.
- To facilitate maintenance and allow access to the various parts, we recommend that you provide sufficient space all the way around the hydraulic unit.

# 4. Piping diagrams

## 4-1. Model: WSEP100KR3

- 1 heating circuit

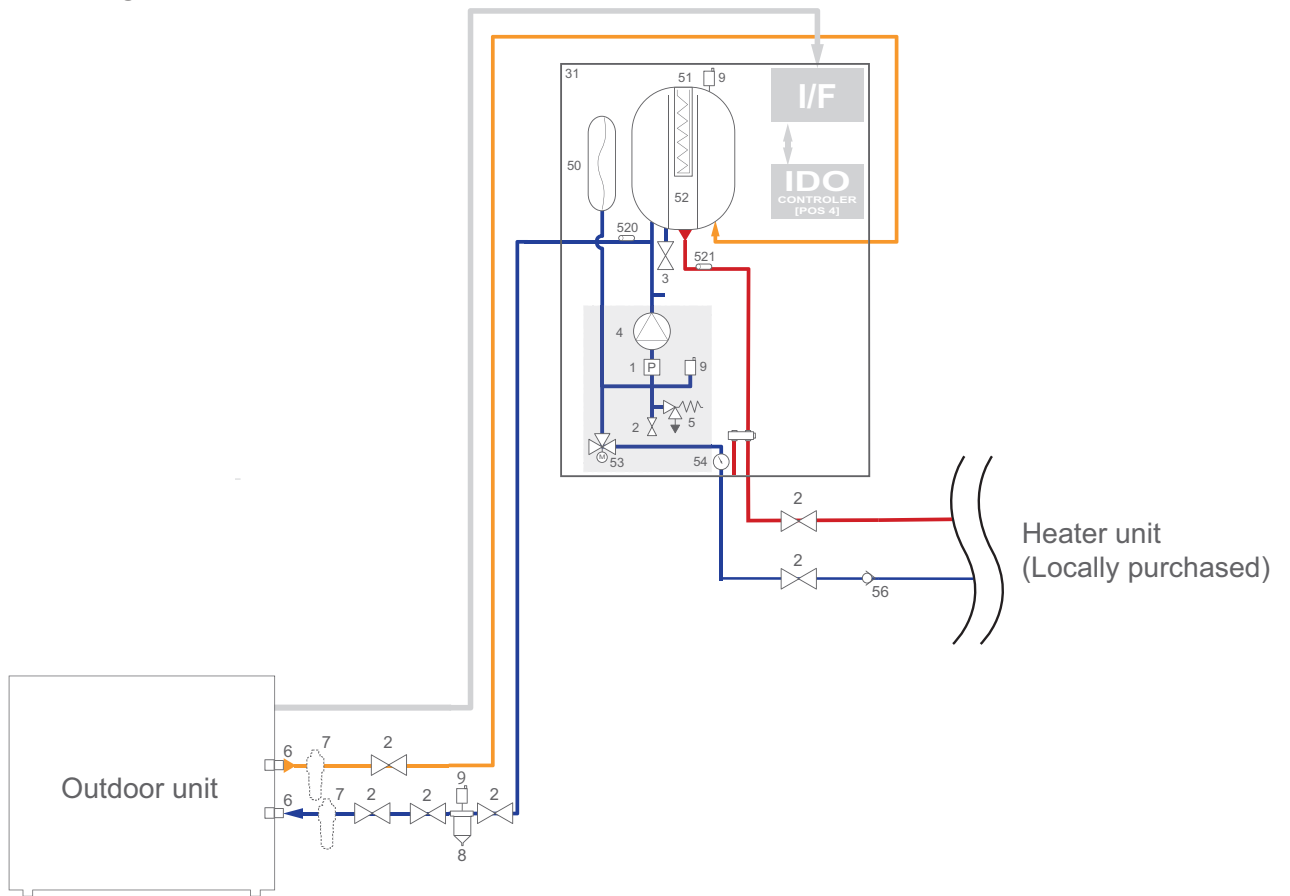

- 1 - Water pressure sensor (Value)
- 2 - Valve
- 3 - Drain valve
- 4 - System pump
- 5 - Safety valve
- 6 - Connection
- 7 - Antifreezing valve
- 8 - Sediment trap
- 9 - Air vent valve

- 31 - Hydraulic unit 1 service
- 50 - Expansion vessel
- 51 - Electrical backup
- 52 - Decoupling bottle
- 53 - Directional valve
- 54 - Manometer
- 56 - No-return valve

- 520 - Return temp. sensor (heating circuit)
- 521 - Flow temp. sensor (heating circuit)

HYDRAULIC UNIT

HYDRAULIC UNIT

• 1 heating circuit with DHW

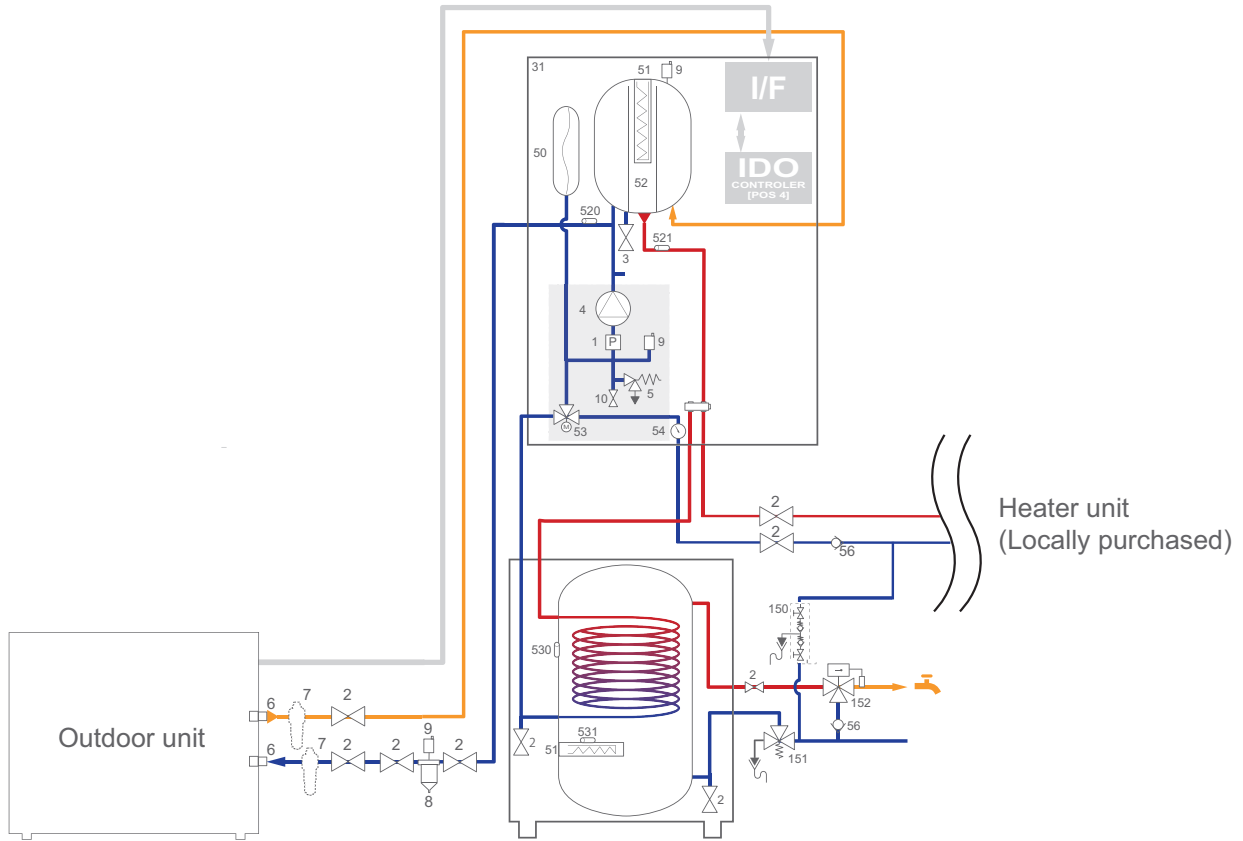

- |                                   |                               |   |
|-----------------------------------|-------------------------------|---|
| 1 - Water pressure sensor (Value) | 31 - Hydraulic unit 1 service | 520 - Return temp. sensor (heating circuit) |
| 2 - Valve                         | 50 - Expansion vessel         | 521 - Flow temp. sensor (heating circuit)   |
| 3 - Drain valve                   | 51 - Electrical backup        | 530 - DHW temp. sensor                      |
| 4 - System pump                   | 52 - Decoupling bottle        | 531 - DHW electrical backup thermal safety  |
| 5 - Safety valve                  | 53 - Directional valve        |   |
| 6 - Connection                    | 54 - Manometer                |   |
| 7 - Antifreezing valve            | 56 - No-return valve          |   |
| 8 - Sediment trap                 |                               |   |
| 9 - Air vent valve                |                               |   |

• 2 heating circuits

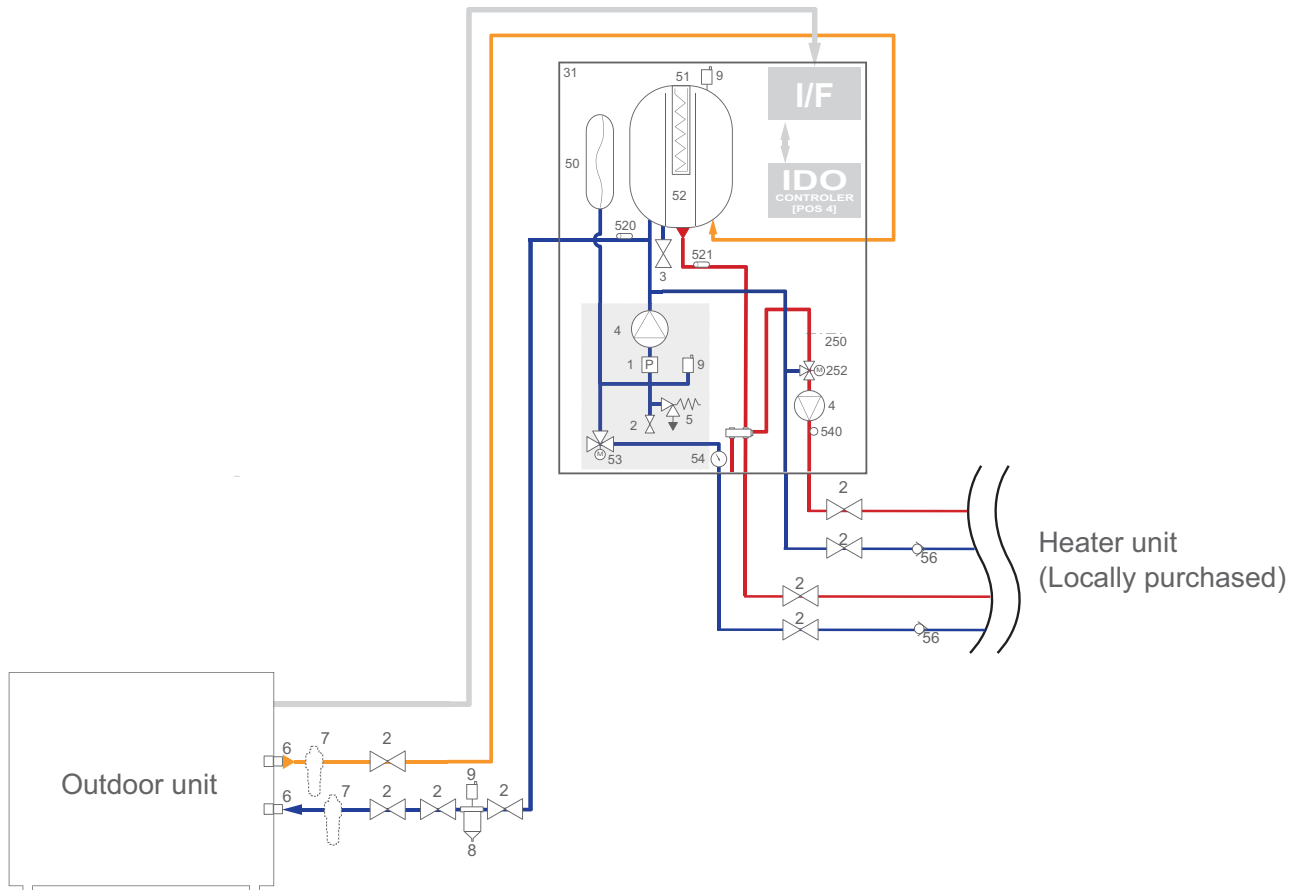

- |                                   |                               |   |
|-----------------------------------|-------------------------------|---|
| 1 - Water pressure sensor (Value) | 31 - Hydraulic unit 1 service | 250 - 2 circuits kit                        |
| 2 - Valve                         | 50 - Expansion vessel         | 252 - Mixing valve                          |
| 3 - Drain valve                   | 51 - Electrical backup        | 520 - Return temp. sensor (heating circuit) |
| 4 - System pump                   | 52 - Decoupling bottle        | 521 - Flow temp. sensor (heating circuit)   |
| 5 - Safety valve                  | 53 - Directional valve        | 530 - DHW temp. sensor                      |
| 6 - Connection                    | 54 - Manometer                | 531 - DHW electrical backup thermal safety  |
| 7 - Antifreezing valve            | 56 - No-return valve          |   |
| 8 - Sediment trap                 |                               |   |
| 9 - Air vent valve                |                               |   |

# 5. Wiring diagrams

## 5-1. Model: WSEP100KR3

HYDRAULIC UNIT

HYDRAULIC UNIT

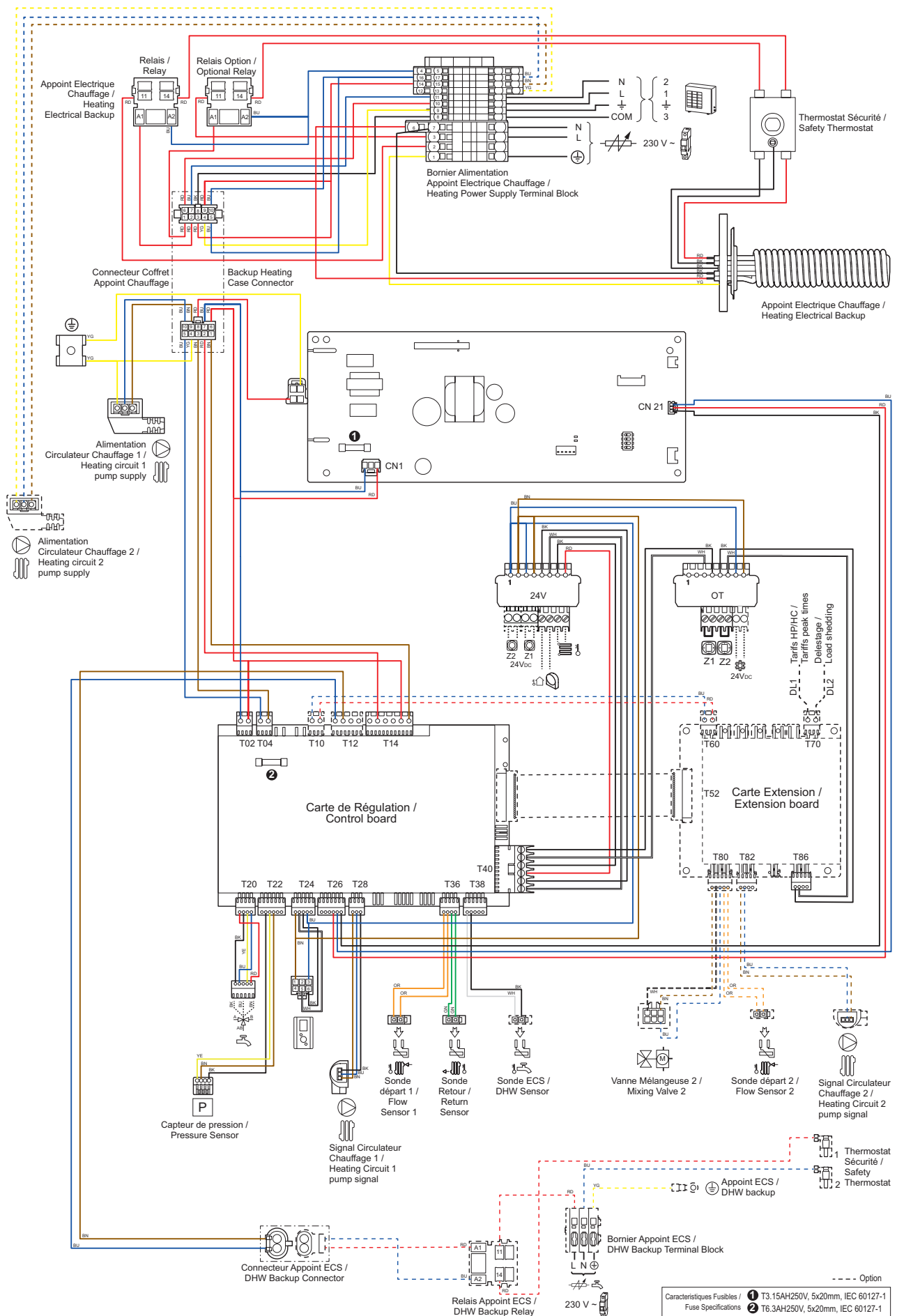

## 6. Hydraulic connections

### 6-1. Outdoor unit

Connect the pipe of the outdoor unit to the hydraulic unit respecting the direction of flow.

#### ⚠ CAUTION

- Install a sediment trap (supplied) on the heating return circuit in the manner suggested.
- Install antifreeze valves (optional/not supplied) on the hydraulic circuit in the recommended direction. If the antifreeze valves are triggered, check the electrical backup safety thermostat before restarting.

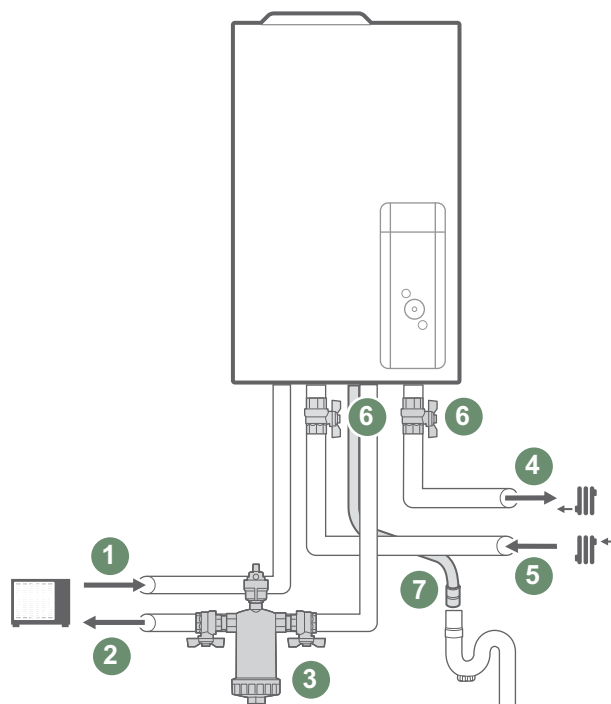

- 1 - Outdoor unit to indoor unit connection.  
 2 - Indoor unit to outdoor unit connection.  
 3 - Sediment trap.

- 4 - Heating return (1 circuit).  
 5 - Heating flow (1 circuit).  
 6 - Shut-off valve (not supplied).  
 7 - Drain pipe.

#### • Length and diameters of hydraulic pipes

Maximum pipe length: 30 m

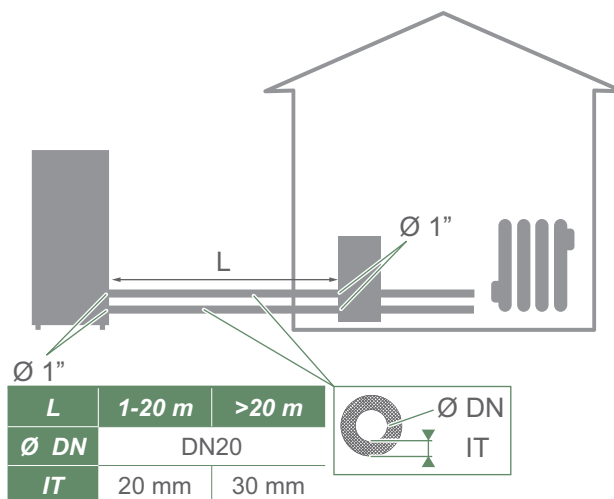



## 7. Electrical connections

### 7-1. Overview

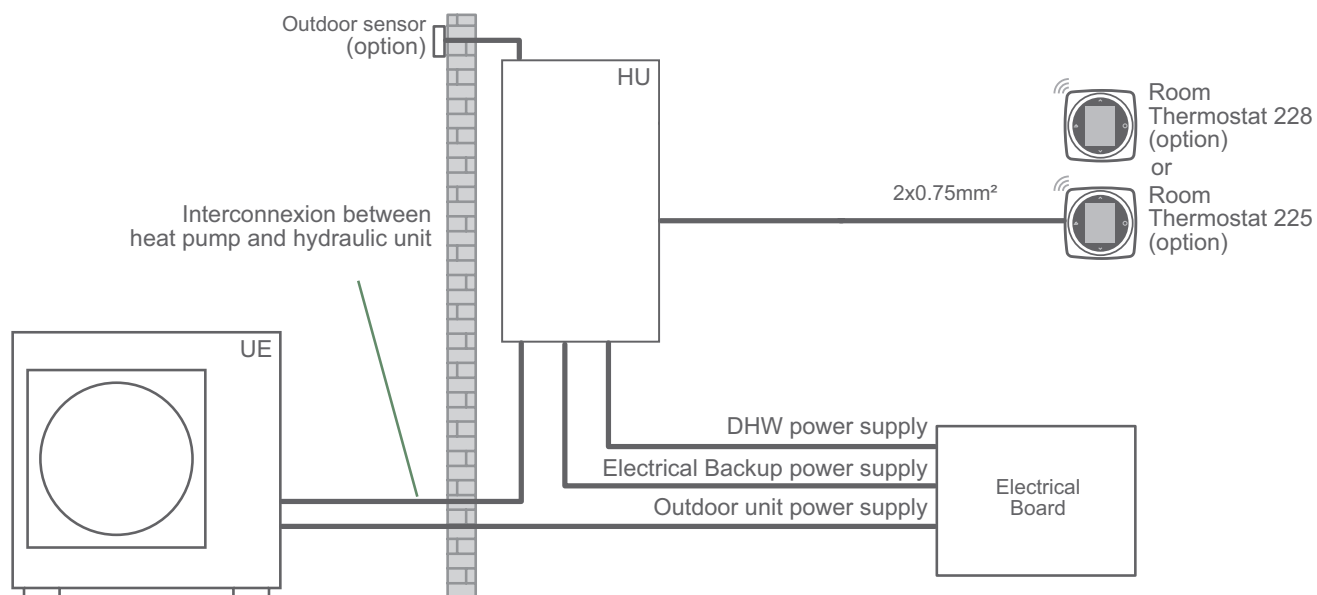

### 7-2. Cable dimensions and protection rating

These cable dimensions are provided for information purposes only and do not exempt the installer from checking that these dimensions match requirements and comply with current standards.

- **DHW power supply**

The DHW section is powered directly via a 3G 1.5 mm<sup>2</sup> cable (phase, neutral, earth).

Protection by rated circuit breaker [16 A, C curve].

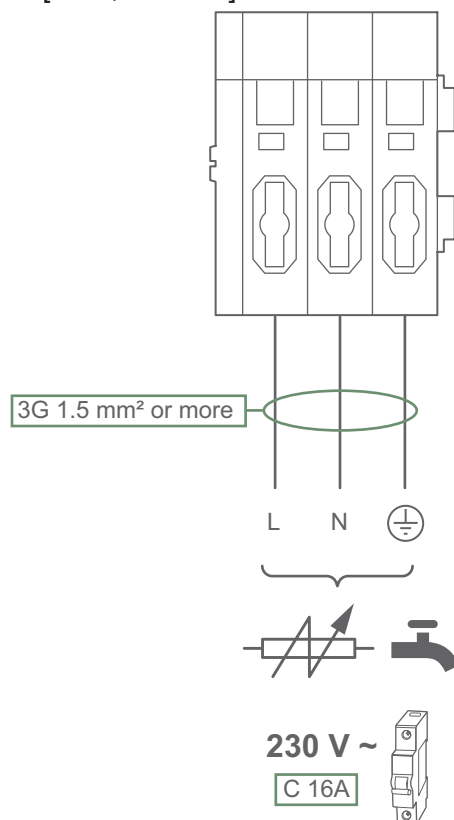

- **Interconnection between the hydraulic unit and the outdoor unit**  
The hydraulic unit communicate with the outdoor unit via a 4G 1.5 mm<sup>2</sup> cable (phase, neutral, earth).
- **Electrical backup power supply**  
The hydraulic module includes an electric backup installed in the heat exchanger.

Electrical backup		Electrical backup power supply	
Power	Normal intensity	Connecting cable (phase, neutral, earth)	Circuit breaker rating/C curve
3 kW	13 A	3G 2.5 mm <sup>2</sup>	16 A
2 × 3 kW (option)	26.1 A	≥ 3G 4.0 mm <sup>2</sup>	32 A

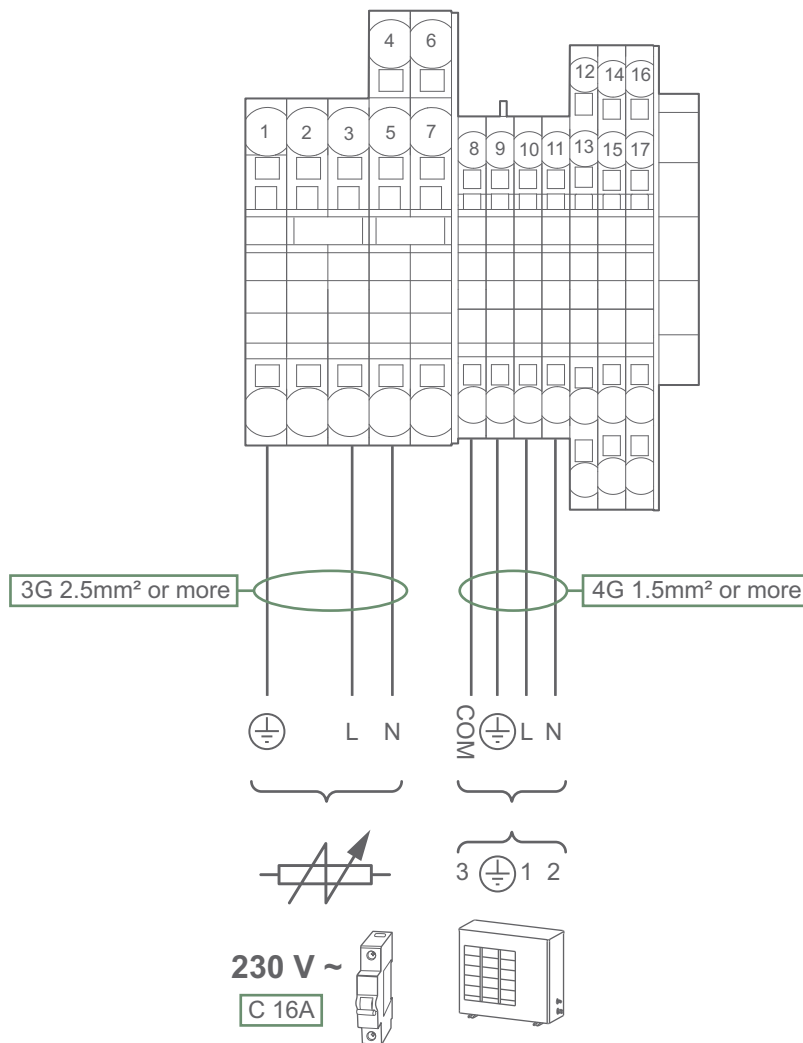

## 8. Hydraulic performance







### 8-1. Model: WSEP100KR3

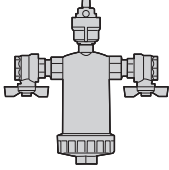
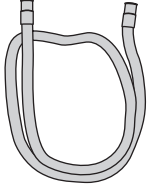

## 9. Safety devices

Type of protection	Protection form		Model
			WSEP100KR3
Circuit protection	Current fuse (PCB)		250 V, 3.15 A
			250 V, 6.3 A
High pressure protection	Safety valve	Activate	3 bar or more Safety valve open
		Reset	—

## 10. Accessories

Shape	Name
	Sediment trap (800μ)
	Drain pipe
	Additional rating label (IT, DE)
	Additional rating label (NL, PL)
	Installation manual
	Quick installation manual
	Installation reference
	User guide



## 3. CONTROL SYSTEM

# CONTENTS

## 3. CONTROL SYSTEM

<b>1. User interface .....</b>	<b>03-1</b>
<b>2. Function table.....</b>	<b>03-3</b>
2-1. Flow setpoint .....	03-3
2-2. User menu .....	03-4
2-3. Installed options.....	03-7
2-4. Domestic Hot Water .....	03-10
2-5. Heating/Cooling .....	03-11
2-6. Heat pump .....	03-13
2-7. Additional functions .....	03-14
2-8. Radio network.....	03-16
2-9. Diagnosis.....	03-17



# 1. User interface

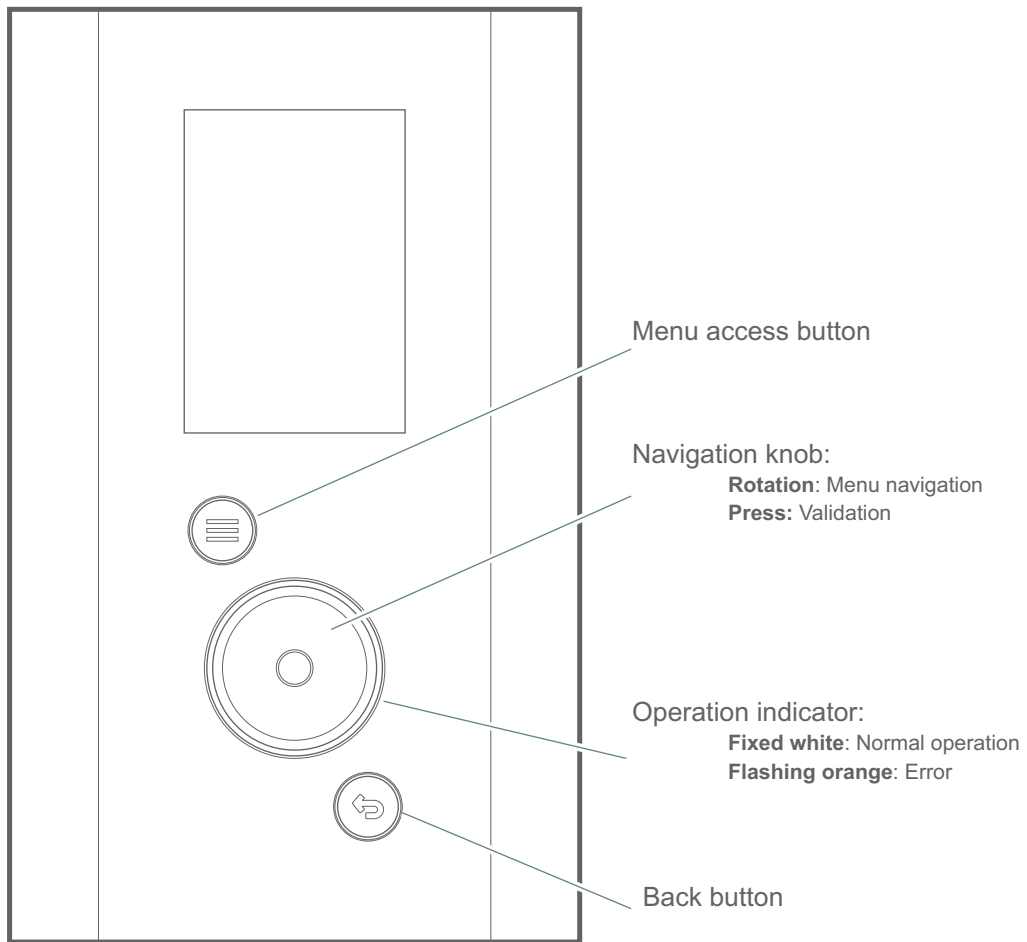

• Display description

- 1 Connectivity
- Attenuation mode
- Planned absence
- Emergency mode
- Outdoor temperature
- Installer Menu
- 2 Normal operation
- Warning
- Error

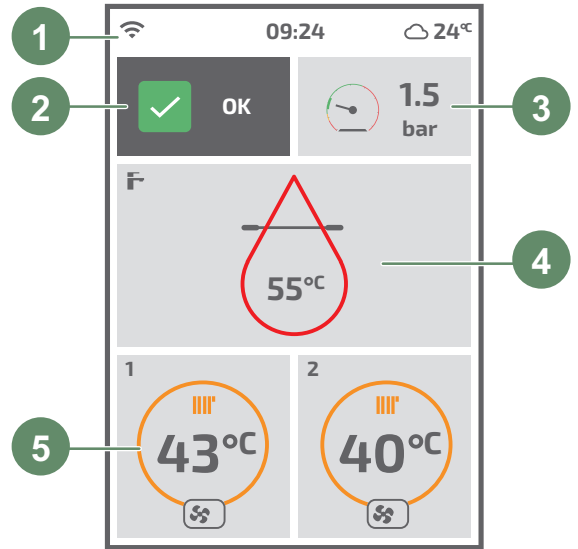

- 3 Pressure indicator

- 4 **55°C** DHW setpoint
- Remaining hot water

- DHW on
- Heating in progress
- (Grey) Off / Frost protection

- 5 **43°C** Flow temperature setpoint

Operation :

- (Orange) Heating
- (Blue) Cooling
- (Grey) Off / Frost protection

Mode :

- Heating
- Cooling
- Absence
- Floor drying

Product by :

- Heat pump
- Electric backup
- Heat pump + Electric backup
- Heat pump + Boiler
- Boiler

## 2. Function table

There are 2 access levels:

- U: End user level
- I: Commissioning level (installer start-up)

### 2-1. Flow setpoint

#### ► WITH room thermostat

Heat pump operation is controlled by the room thermostat.

The circuit water temperature setpoint is calculated by the thermostat and then communicated to the heat pump.

	<b>Settings on thermostat</b>
	• Heating settings
	- Mode choice.
	- Set room setpoints.
	- Time programming setting

#### ► WITHOUT room thermostat

The heat pump's operation is subject to the temperature control.

The heating circuit water temperature setpoint is adjusted according to the outdoor temperature.

If there are thermostatic valves on the installation, these must be fully open or set higher than the normal temperature setpoint..

#### ▼ Setting

##### Flow temperature setpoint setting

This setting is made directly via the interface.

Heating / Cool	Circuit 1	Heating
----------------	-----------	---------

Circuit 1 Heating	
Flow setpoint limits	
Min: 12°C	Max: 50°C
Temperature control	
Weather compensation	
Flow temp at -10°C outside	40°C
Flow temp at 20°C outside	20°C

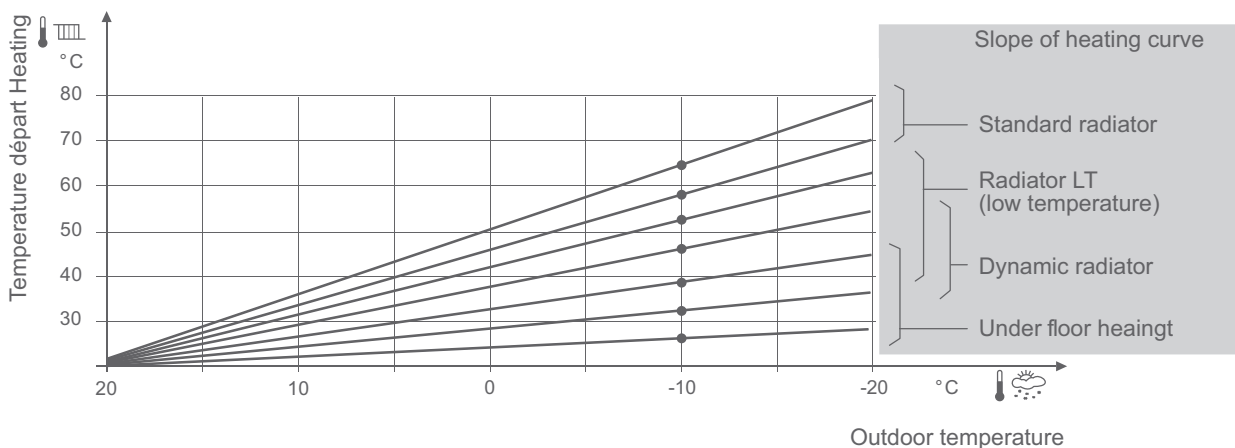

## 2-2. User menu

Access	Function		Setting range or Display	Setting increment	Factory setting
U	Active functions	Domestic hot water	On/Off	---	---
U		Circuit 1/2	On/Off/Heat/Cool	---	---
U		Emergency mode	Active/Inactive	---	---
U	Domestic hot water	Heating mode	Comfort/Eco	---	---
U		Temperature	45°C... 65°C	1°C	---
U	Away mode	Start of away mode (Day/Month/Time)	---	---	---
U		End of away mode (Day/Month/Time)	---	---	---
U	Energy monitoring	Consumed energy	For heating/For cooling/For hot water/ Total	---	---
U		Produced energy	For heating/For cooling/For hot water/Total	---	---
U	Language		Danish/Deutsch/Ukrainian/English/Estonian/French/Italian/Lithuanian/Dutch/Polish/Romanian	---	---
U	Date/Time		---	---	---
U	Circuit names		---	---	---
U	Wi-Fi	Wi-Fi status	---	---	---
U		Wi-Fi code	---	---	---
U		Disconnect	---	---	---
U	Software version	User interface version	---	---	---
U		Wi-Fi interface version	---	---	---
U		Control board version	---	---	---

• **Domestic hot water**

This function guarantees hot water at all time and reduces the consumption.



– **Comfort:** provides maximum comfort by ensuring a large quantity of hot water at all times.

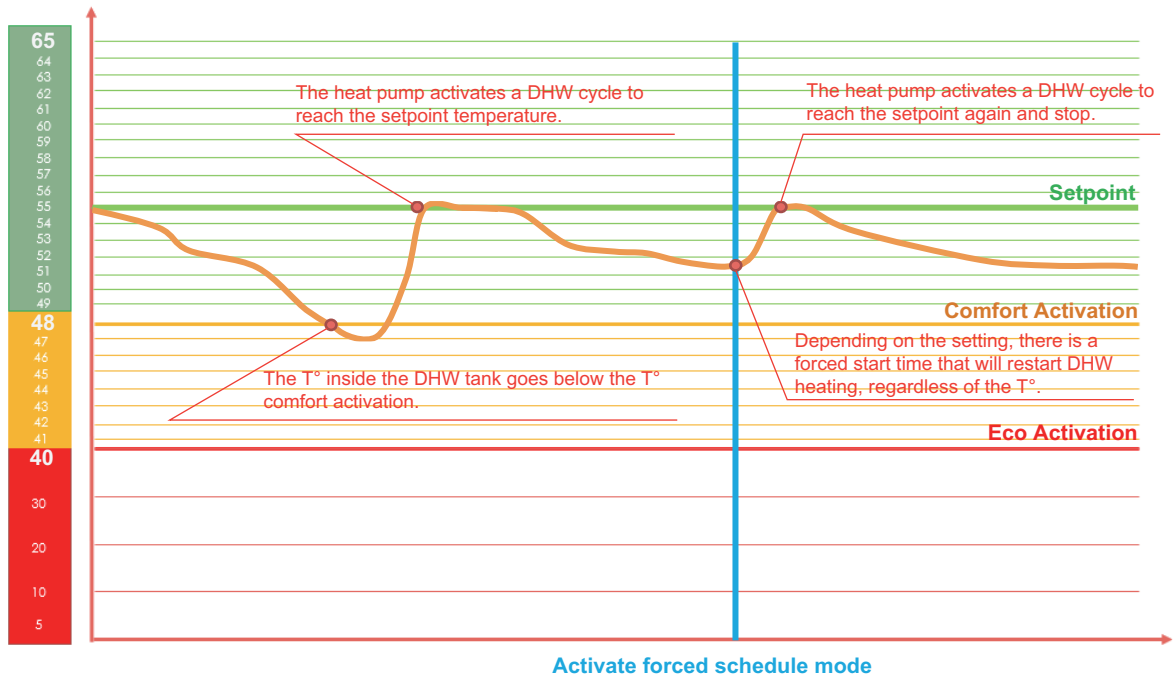

DHW Activation by Comfort T°

- **Eco:** for maximum savings while ensuring comfortable heating and sanitary conditions.

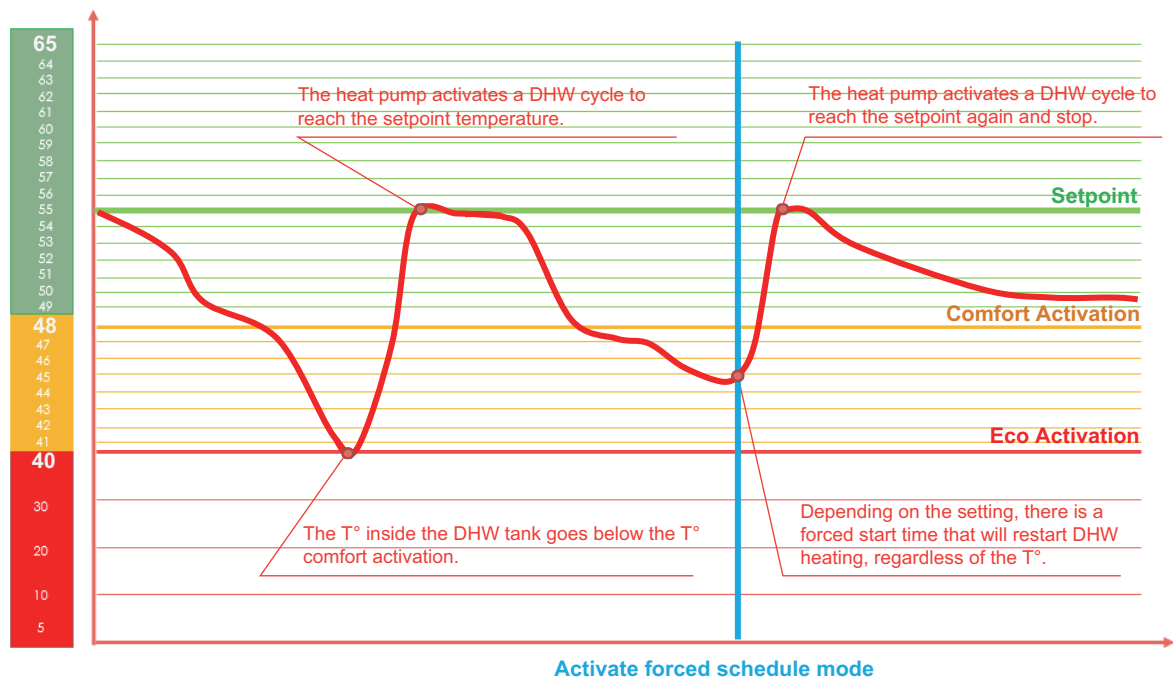

### DHW Activation by Eco T°

- **Emergency mode**  
If the heat pump is not operating properly, an emergency operation can be maintained. The emergency operation enables the installation to be run with the available heaters (flow, DHW tank). In this case, the compressor will remain off.
  - **Away mode**  
It will set heating and DHW mode to the frost protection\* during the selected period:
    - If you activate away mode on HMI:  
You can choose start and end time/date
    - If you activate away mode on Room thermostat (option):  
You can choose start and end time/date, as well as room setpoint during away period.
- \*: The protection mode automatically prevents an excessively sharp drop in room temperature.

## 2-3. Installed options

Access	Function	Setting range or Display	Setting increment	
	Installed options	Outdoor unit model	XX kW	1 kW
		Electrical heater	None/3 kW/3 kW + 3 kW	---
		Number of circuits	1/2	---
		Circuit X: Name	Circuit 1/Day/Night/Ground floor/Floor/Living areas/Bedrooms	---
		Circuit X: Emitters type	Radiators/Floor/Ceiling/Fan convector	---
		Circuit X: Comfort served	Heating/Heating and Cooling	---
		Outside Temperature (Information depending on outside sensor location)	From Outdoor Unit/From remote sensor	---
		Safety input	Normally Open/Normally Closed	---
		Ext 1 input: Type of functions	None/Off -peak hours/Photovoltaics/Smart Grid	---
		External input 1 Switching settings	0 V/230 V	---
		Ext 2 input: Type of functions	None/Power shedding/Cooling switch/Smart Grid	---
		External input 2 Switching settings	0 V/230 V	---
		If power shedding order/Power shedding	Compressor Allowed/ Compressor Forbidden	---

- **Outside temperature**

If UTW-KESXQ (option) is connected to indoor unit, 'From remote sensor' can be activated.

UTW-KESXQ (option) is used in case the outside temperature from the outdoor unit is not representative. For example, The outside temperature can not be detected as current temperature because there is outdoor unit in a sunny spot.

- **Ext 1 input: Type of functions:**

External input are an option available with the 2-zone kit or Extension regulation kit (option: UTW-KREXQ)

- **Component location**

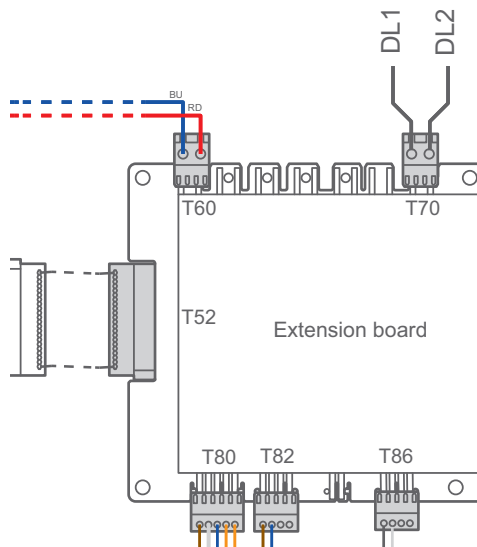

- **Function**

Setting DL1	Signal on DL1	None	Off-peak hours	Photovoltaics
230 V	230 V	No effect	DHW in Comfort mode	DHW forced ON Setpoint: Maximum of DHW T° (65°C)*
	0 V	No effect	DHW in Eco mode	No effect
0V	230 V	No effect	DHW in Eco mode	No effect
	0 V	No effect	DHW in Comfort mode	DHW forced ON Setpoint: Maximum of DHW T° (65°C)*

\*: Photovoltaics function is activated when the DHW is off or load shedding (DL2) is activated.

- **Off-peak hours**

This function indicates you that cheap electricity is currently available.

The DHW charges to comfort setpoint to optimize power consumption from an economical point of view.

- Connect the “Power Provide” contact to input DL1 of the T70 connector.
- Set the “External input 1: Type of functions” to “Off-peak hours” in the menu “Installed Options”.
- By default: 230 V (DL1): Information "Off-peak hours" activated.  
The DHW is produced at the comfort setting.

- **PhotoVoltaics**

When there is excess power available from the local Photovoltaics installation then, this function is activated. The DHW is in charge to the max temperature (65°C) with only electrical heater.

- Connect the “Power Provider” contact to input DL1 of the connector T70.
- Set the “External input 1: Type of functions” to “PhotoVoltaics” in the menu “Installed Options”.
- By default: 230 V (DL1): Information "PhotoVoltaics" activated.  
The electric backup for the domestic hot water tank is activated up to a maximum temperature of 65°C.

- **Smart Grid**

- Connect the 2 power contacts “Power suppliers” to inputs DL1 and DL2 of connector T70.
- Set the “External input 1: Type of functions” to “Smart Grid” in the menu “Installed Options”.
- By default: Smart grid operation is as follows.



DL1	DL2	Behavior
0 V	0 V	Normal
230 V	0 V	Idem Power shedding
0 V	230 V	Idem Off-peak hours
230 V	230 V	DHW forced ON at the maximum of DHW setting

- **Ext 2 input: Type of functions:**

External input are an option available with the 2-zone kit or Extension regulation kit (option: UTW-KREXQ)

Smart Grid is automatically set if DL1 is also set in Smart Grid.

- **Component location**

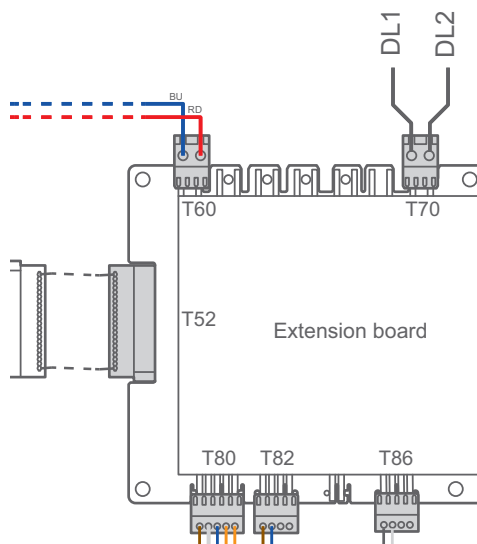

- **Function**

- **Power shedding**

Electrical heaters are locked and Compressor can be available or locked due to high cost electricity.

Setting DL2	Signal on DL2	Compressor	Outdoor unit	Heating electrical backup	DHW electrical backup
230 V	230 V	Authorized	Yes	No	Yes
	0 V	Forbidden	No	No	Yes
0 V	230 V	Forbidden	No	No	Yes
	0 V	Authorized	Yes	No	Yes

- **Cooling switch**

It is possible to control the changeover from “Heating Mode” to “Cooling Mode” via an “external control input”.

- Connect the external control box to the input DL2 of the connector T70.
- Set the “External input 2: Type of functions” to “Switch to cooling” in the menu “Installed Options”.
- By default: Heating/Cooling mode is as follows.  
0 V on DL2: Heating mode  
230 V on DL2: Cooling mode
- Demand management by circuit mode via room thermostat input(s).

**⚠ CAUTION**

Do not connect the ON/OFF thermostat to the external control setting.

## 2-4. Domestic Hot Water

Access	Function		Setting range or Display	Setting increment	Factory setting
	Settings	Heating mode	Comfort/Eco	---	Comfort
		Temperature	47°C... 55°C... Temperature max	1°C	55°C
		Temperature max	Temperature... 65°C	1°C	65°C
		Forced load	Auto/Manual	---	Auto
		Forced heating 1/2	Set the time	15 min	---
	Anti-Legionella	Weekly protection	Enabled/Inactive	---	Inactive
		Cycle time	Setting the day and time	15 min	---
		Temperature	55°C... 60°C... 65°C	1°C	60°C

- **Forced load, Forced heating 1/2**

- If you selected Auto in Forced load:  
Forced load will be started each day at 00:00.

- If you selected Manual in Forced load:  
You can choose start time in Forced heating 1/2.

When Forced load is activated, DHW will be forced ON. For details, refer to "[Domestic hot water](#)" on page 03-5.

- **Anti-Legionella**

The indoor unit has a legionella function designed for protection against legionella in the storage tank and the pipes.

The legionella function can be activated on a fixed day of the week.

With this setting, heating up to the legionella setpoint occurs on the scheduled day of the week, regardless of the storage tank temperatures during the previous period.

## 2-5. Heating/Cooling

Access	Function		Setting range or Display	Setting increment	Factory setting
	Heating	Flow setpoint limits	Min: 10°C... 20°C	1°C	---
			Max: 20°C... 65°C	1°C	---
		Temperature control Refer to flow setpoint	Weather compensation/ Smart Adapt	---	Weather compensation
		Flow temp at -10°C outside	Flow temp at 20°C outside... 80°C	1°C	---
		Flow temp at 20°C outside	10°C... Flow temp at -10°C outside	1°C	---
		Room temperature influence	10%... 50%... 100%	5%	50%
	Cooling	Flow setpoint limits	Min: 10°C... 35°C	1°C	---
		Temperature control Refer to flow setpoint	Weather compensation/ Smart Adapt	---	Weather compensation
		Flow temp at 25°C outside	Flow temp at 20°C outside... 35°C	1°C	---
		Flow temp at 35°C outside	7°C... Flow temp at -10°C outside	1°C	---
	Thresholds in Auto	Switch to heating at	15°C... 20°C	1°C	---
		Cooling switch at	21°C... 30°C	1°C	---

### • Weather compensation

Room temperature will be controlled according to Heating Curve shown below.

Heating curve slope will be changed automatically by choosing emitter type.

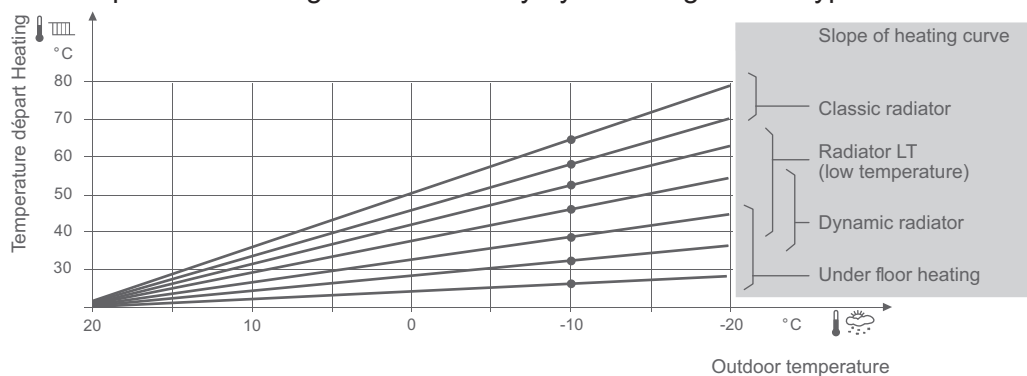

### • Smart Adapt

This function enables to adapt continuously to disturbances, whether positive (free input: oven, sunshine, activity...) or negative (opening a window...).

This function will need Room thermostat (option).

### • Flow temp at -10°C outside, Flow temp at 20°C outside

Heating curve slope in weather compensation will be affected by setting these parameters.

It is calculated with a linear function between two points (-10°C and +20°C)

- **Room temperature influence**

- **10...95%: Control according to outdoor conditions with room influence**

The difference between the room temperature and the setpoint value is measured and taken into account for temperature control. This enables taking into account possible heat inputs and ensures a more accurate room temperature control. Thus the differences with the room temperature are taken into account and the room temperature becomes more stable. The influence of the difference is defined as a percentage. The better the installation in the reference room (accurate room temperature, correct installation location, etc.) the higher will be the value that can be set.

**Recommend:**

- Radiator 70%
- Underfloor heating 30%
- Fan coil no room thermostat

- **100%: Control according to room temperature only**

The flow temperature is adjusted according to the room temperature setpoint, the current room temperature and its evolution. A slight increase in room temperature, for example, causes an immediate drop in the flow temperature.

- **Flow temp at 25°C outside, Flow temp at 35°C outside**

Heating curve slope in weather compensation will be affected by setting these parameters. It is calculated with a linear function between two points (25°C and 35°C).

- **Auto thresholds**

In AUTO mode the balancing between heating/cooling is automatic according the outdoor temperature.

## 2-6. Heat pump

Access	Function		Setting range or Display	Setting increment	Factory setting
	Compressor	Minimum off time	3 min... 8 min... 20 min	1 min	8 min
		Overrun	10 s... 30 s... 600 s	10 s	30 s
	For DHW production	Maximum DHW charging time	90 min... 120 min... 180 min	10 min	120 min
		Back to Heating/Cooling	10 min... 30 min... 180 min	10 min	30 min
	Electrical heater	Outdoor temperature threshold	Inactive/-15°C... 2°C... 10°C	1°C	2°C
		Switching threshold	0°C min... 10°C min... 500°C min	10°C min	10°C min
	Circulators	Outdoor unit Pump speed	60%... 100%	10%	100%
		System pump speed	70%... 100%	10%	100%
		Circuit 2 Pump speed	70%... 100%	10%	100%

- **Compressor**

- **Minimum off time**

The compressor remains switched off for the minimum period of time set here. Switch-off temperature maximum if the flow or the return temperature exceeds the maximum switch-off temperature, the compressor will be switched off. The heat pump is switched on again when the temperature at both sensors has dropped by the “Switching difference return temperature” below the maximum switch-off temperature and the minimum off time has elapsed.

- **Overrun**

Overrun time is about all the pumps keep running this overtime after compressor stops.

- **For DHW production**

- **Maximum DHW charging time**

During charging, the room heating may be stopped or insufficient. Therefore it is often advisable to limit the charging process timewise to enable heating. If “---” has been selected the charging time limitation will be deactivated. The DHW will be heated to the nominal setpoint, even if the room heating has not received enough power in the meantime. If a value between 90 and 180 is selected, charging will be suspended after the time period set in minutes, and will remain suspended over that time before resuming. The generator power remains available in the meantime to heat the room. This cycle is repeated until the DHW nominal setpoint has been reached.

**NOTE:** When the room heating is stopped (summer mode, economy function, etc.), DHW charging remains active, regardless of the setting.

- **Back to Heating/Cooling**

If “Back to Heating/Cooling” time has elapsed, then DHW operation is resumed.

## 2-7. Additional functions

Access	Function		Setting range or Display	Setting increment	Factory setting
	Attenuation mode	Compressor limitation	Enabled/Inactive	---	Inactive
		Max allowed speed	10%... 95%	10%	---
		Active as	Outdoor > -15°C... 10°C	1°C	---
		Period 1/2/3	Set the period	15 min	---
	Air purge cycle		---	---	---
	Floor drying circuit 1	Drying	Off/Manual for 25 days/ Progressive 18 days + Shock 7 days	---	Off
		Flow temperature setpoint	20°C... 55°C	1°C	---

- **Attenuation mode**

This function can limit compressor modulation for low noise.

**Example:**

- Compressor limitation: Enabled
- Max allowed speed: 50%
- Active as: Outdoor > -5°C (current outdoor temp = 0°C)
- Period 1: from 22:00 to 5:00

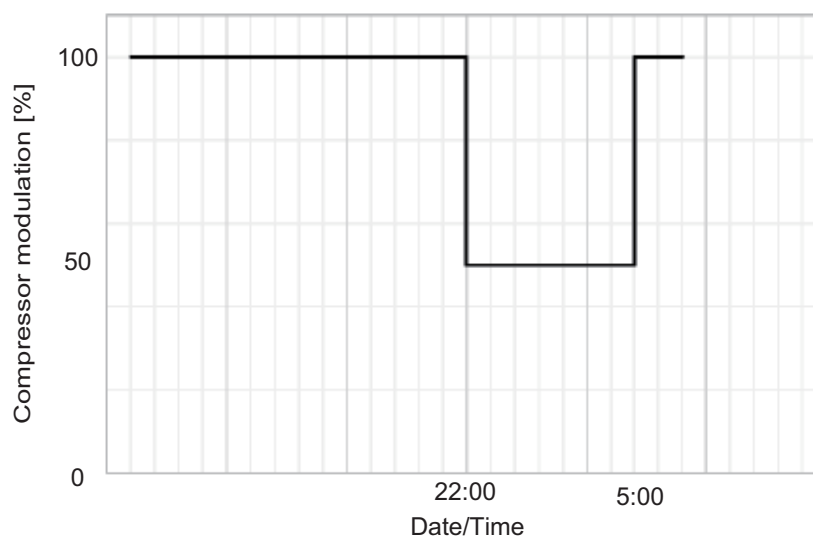

## • Air purge cycle

The air purge cycle takes approximately 4 minutes.

Never interrupt this cycle.

(During the purge cycle, the circulator alternates between operating and stopping phases lasting 5 seconds (5 s on, 5 s off...).

The valve alternates every 30 seconds between the heating and sanitary circuits.)

Open all system drains to evacuate air from the pipes.

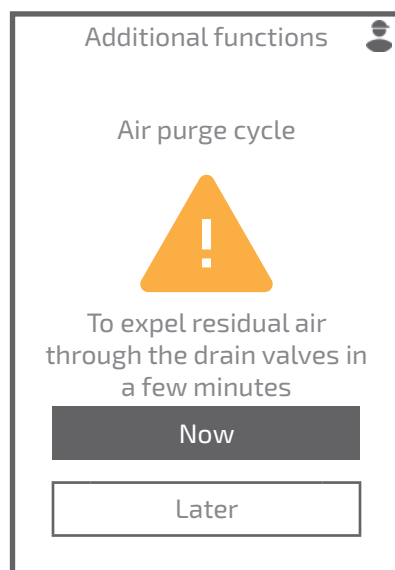

## • Floor drying circuit 1

Observe the building manufacturer's standards and instructions. Correct operation of this function is only possible with a correctly installed system (Hydraulics, Electricity, and Settings).

The function can be interrupted early by setting to Off.

**NOTE:** This function is only usable with an underfloor heating system.

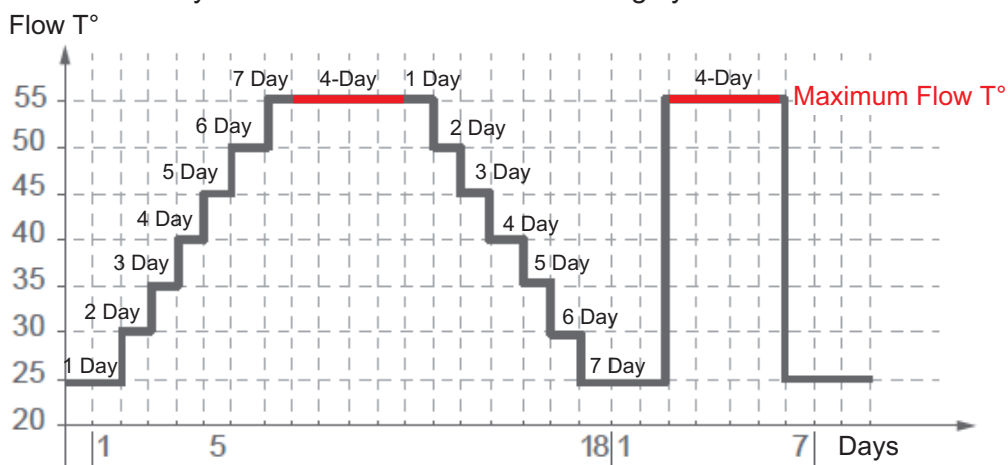

- A 28-day cycle is initiated for the floor drying process.
- 18 Days progressive.
- The water temperature will incrementally rise by 5°C each day, reaching 50°C on day 7.
- The temperature is maintained at 55°C for 4 days.
- Subsequently, there will be a gradual decrease of 5°C per day for 7 days, reaching 25°C.
- A new 7-day cycle will commence.
- The temperature will be raised to 55°C in a single step.
- This temperature will be maintained for 4 days.
- Subsequently, the temperature will return to 25°C.
- Progressive for 18 days, followed by a 7-day intensive treatment.

## 2-8. Radio network

Access	Function	Setting range or Display	Setting increment	Factory setting
	Add Thermostat	---	---	---
	Add Repeater	---	---	---
	Advanced Controls: Features	---	---	---
	Reset Network	---	---	---

- **Add thermostat**

For details, refer to the thermostat manuals for the following optional parts.

- UTW-C225XQ
- UTW-C228XQ

- **Add Repeater**

Install a radio repeater halfway between this control box and the thermostat.

**NOTE:** For the radio repeater, use the ATLANTIC product (Model: 139117) or equivalent (Locally purchased).

- **Advanced Controls: Features**

Provides status and the technical information on the radio network.



## 2-9. Diagnosis

Access	Function	Setting range or Display	Setting increment	Factory setting
	Error history		---	---
	Indoor Unit	Displays the status of the various functions and actuators.	---	---
	Outdoor unit		---	---
	Operation Counters		---	---
	Test Outdoor unit	Mode:	Heating/Cooling	---
		Compressor modulation	Off/100%	Off
	Actuator test	System pump Outdoor unit	Off/60%...100%	10%
		System pump	Off/70%...100%	10%
		Electrical heater	Off/On	---
		Circuit 2 Pump speed	Off/70%...100%	10%
		Mixing valve Circuit 2	Closed/Opened 10%...100%	10%
		DHW electrical heater	Off/On	---
		Directional valve	Heating/Domestic hot water/ Middle position	---
	Reset	The factory settings, stored in the controller, replace and override the custom personalized programssettings	---	---

- **Actuator test**

These parameters are set to OFF the moment you leave the page or after 30 min without any action on the HMI.